



USA



Solis: The World's 3rd Largest PV Inverter Manufacturer

Ginlong Technologies Co., Ltd.

Developing technology to
power the world with clean energy

**COMPANY
MISSION**



COMPANY PROFILE

Established in 2005, Solis (Ginlong Technologies) stands as the world's third-largest PV inverter manufacturer. As a global provider of solar and energy storage solutions catering to residential, commercial, and utility-scale customers, we deliver value across the solar supply chain. Operating under the Solis brand, our solar inverter product line employs innovative string technology, ensuring top-tier reliability validated through rigorous international certifications.

Solis inverters to each regional market, with dedicated teams of local experts providing exceptional service and support. Our proven bankability has garnered support from leading financial institutions, assuring robust, long-term returns on investment. Collaborating with stakeholders, we are committed to expediting the world's journey towards a more sustainable future.

With over 40 employees in the United States, we are dedicated to the growth and success of our products here. We foster an open ecosystem, working with several leading battery and MLPE/RSD brands to provide choice and flexibility for the consumer.

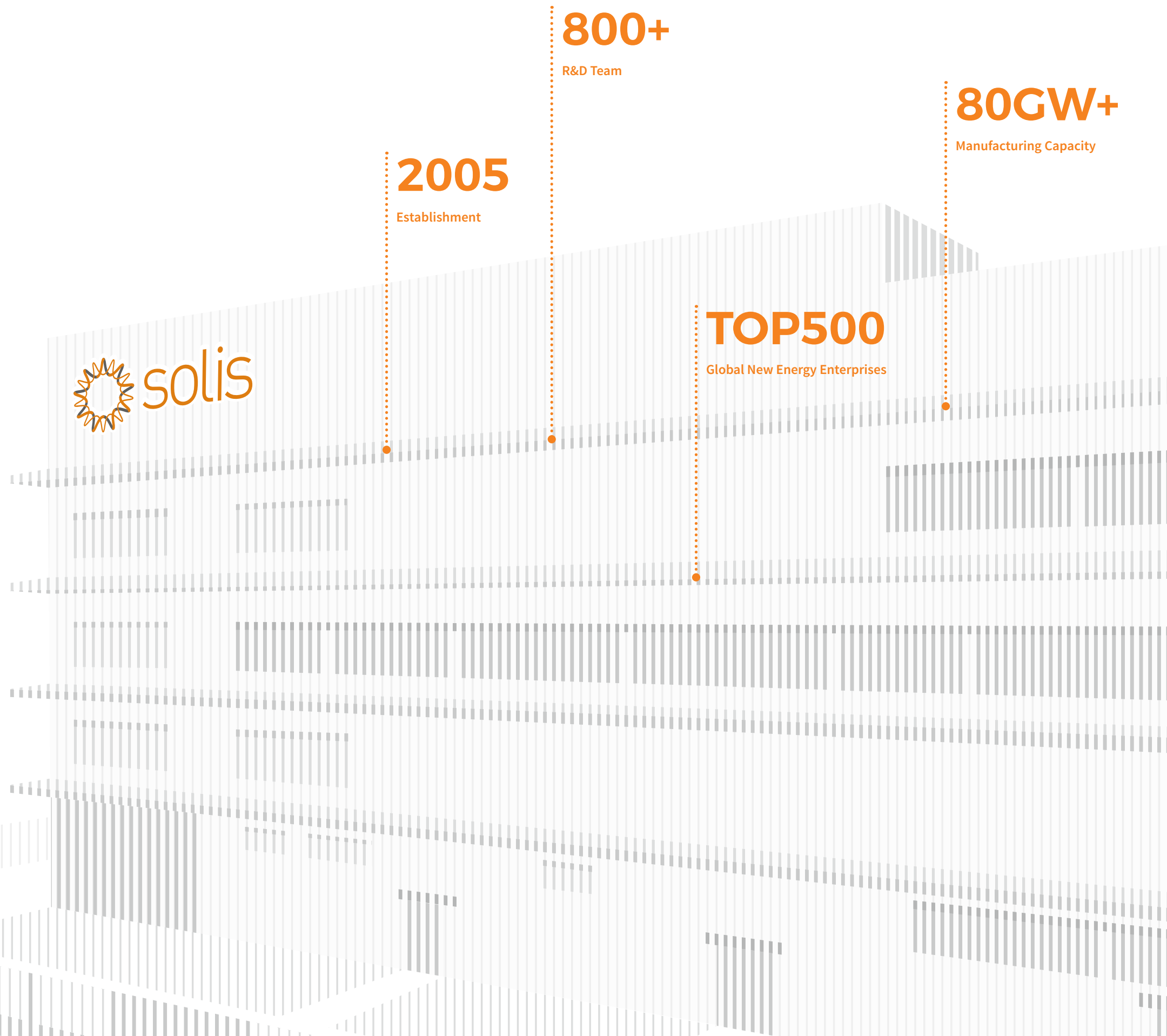

COMPANY HISTORY

2005

Ginlong Technologies established in Ningbo, China

2006

One of the first inverters certified to UK G83

2009

First Asian string inverter to achieve USA UL1741 certification

2010

Second Asian inverter certified to AS4777/AS 3100

2011

Ginlong hosted IEC61400 second annual meeting

2015

Ginlong inverter installed on the Eiffel Tower in Paris

Achieved top 12 inverter sales ranking in Europe

Earned third place ranking in China PV string inverter brand value (2015-2016)

2016

Listed by Asia PV innovation

Awarded Best Distribution Inverter Brand by PVBL

2017

Granted prestigious APVIA Technology Achievement Award (2017-2021)

2018

Single-phase string inverters ranked 2nd in global market shares (Wood Mackenzie)

2019

Ginlong (Solis) listed as a Public Company Stock Code: 300763.SZ

Ginlong (Solis) Ranked Third among Asian Brands by BloombergNEF Bankability

2020

Three-phase string inverters ranked 3rd in global market shares (Wood Mackenzie)

Ginlong Solis won PVBL 2019 Annual Top Global PV Brand Award

2021

National Enterprise Technology Center

Ranked among the top 500 global new energy companies

National technological innovation demonstration enterprise

Excellent after-sales service system certification

Sixth batch of individual champions in 2021 by (MIIT)

2022

The World's 3rd Largest PV Inverter Manufacturer (2021-2022)

No.2 PV Inverter Supplier Among Listed Companies in Shipments in China

National laboratory qualification CNAS certification

2023

Forbes China's Top 50 Innovative Enterprises

2024

Ranks among the top PV brands by EUPD research for 9 consecutive years (2016-2024)



锦浪科技

GINLONG

锦浪科技股份有限公司
GINLONG TECHNOLOGIES CO., LTD.



35 Service Centers

With 35 offices and service centers around the world, including the UK, France, Italy, Netherlands, Spain, Poland, Sweden, Turkey, Germany, Lithuania, Switzerland, Greece, Portugal, Ireland, Austria, Romania, South Africa, China, India, Indonesia, Korea, Myanmar, Malaysia, Philippines, Pakistan, Singapore, Sri Lanka, Thailand, Vietnam, Australia, Brazil, USA, Canada, Mexico and Chile, Solis has a well-established and expanding global presence.

HQ Service Centers



GLOBAL REACH LOCAL EXPERTISE

CONTENTS

P11

Residential Energy Storage Solutions

The Solis residential energy storage family of powerful inverters aim to provide energy storage solutions for PV systems to achieve the goal of a zero-carbon life.

P19

Residential Solar PV Solutions

Solis residential string inverters are cost-effective and efficient residential green power leaders, providing smarter green power solutions for your residential buildings.

P27

Commercial & Industrial Solar PV Solutions

Solis' C&I string inverter product line is broad with a power range cover 25kW - 125kW, providing you with the best industry green power solutions.

P39

Utility Scale Solar PV Solutions

Solis has optimized and innovated the whole process of utility solar PV solutions, integrated PV system design, digital management, and IoT technology.

P51

Export Power Management Solutions

In some countries, local regulations limit the amount of PV power that can be exported to the grid or allow no export. Solis offers two export limitation solutions for single and multiple inverters system.

P55

SolisCloud: Intelligent Solar Energy System Monitoring

The SolisCloud intelligent monitoring system includes hardware and software products and is a comprehensive energy management solution. Hardware products, including data stick, data box, EPM and PLC, etc; transmit to SolisCloud online energy management platform. Real-time monitoring, visualized management and remote O & M of residential, C&I and utility scale solar PV plants.

Residential Energy Storage Solutions



The Solis residential energy storage family of powerful inverters aim to provide energy storage solutions for PV systems to achieve the goal of a zero-carbon life.

Inverter: S6-EH1P(12-16)K03-NV-YD-L-US S6-EH1P(3.8-11.4)K-H-US

Power Hub: Solis Hub-200A-US

MLRSD and Optimizer: Cooperate with

	Brand	Model	Product description (Standard)
MLRSD	APS	RSD-S-PLC	Single input channel 1500V UL/1000V TUV, 1.2m cable, MC4
		RSD-D-15	Dual input channel 1500V UL/1000V TUV, 15A, 2.2m cable, MC4
	Tigo	TS4-A-F	Single input channel 1500VUL/1000VIEC, 15A, 1.2m Cable, MC4
		TS4-A-2F	Dual input channel 1500VUL/1000VIEC,15A, 2.2m Cable, MC4
Optimizer	Tigo (Pending)	TS4-A-O	Single input channel 1500V UL / 1000V IEC,15A, 0.12/1.2m cable, MC4

Noted: Contact manufacture for other connectors and cable length options.

Monitor: S1-W4G-ST/S2-WL-ST/S3-WiFi-ST (WiFi, Cellular, LAN solution)

Residential Energy Storage Solution

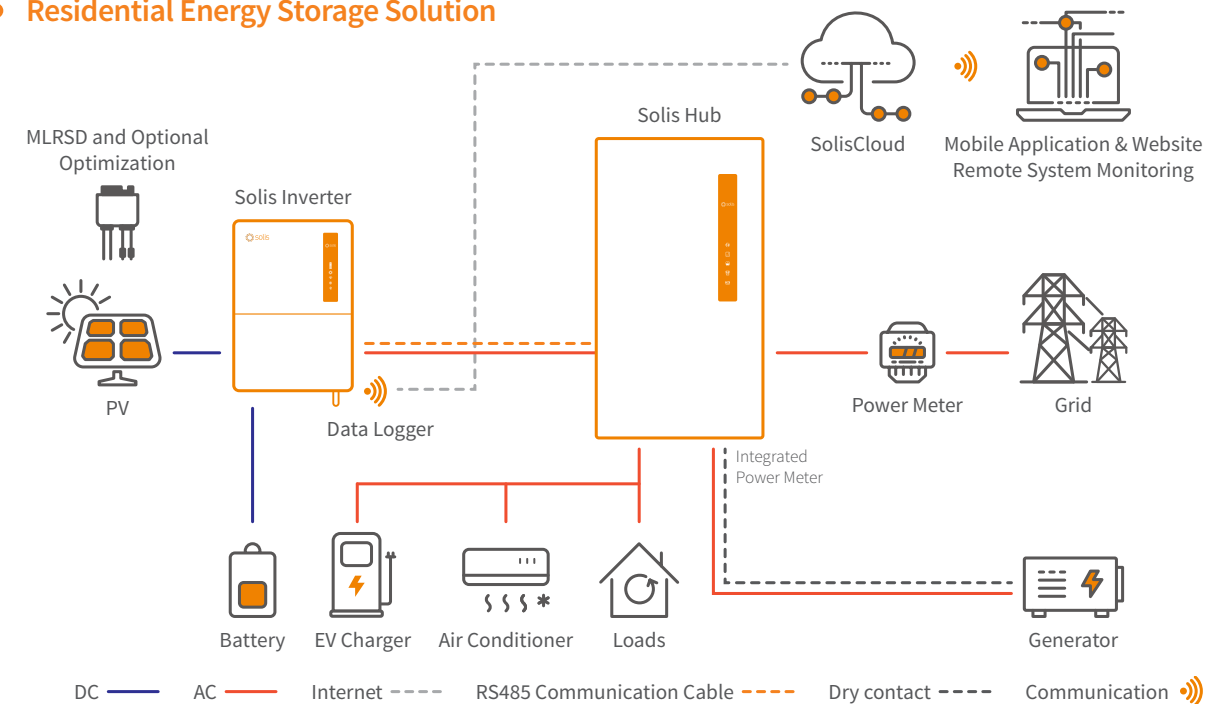

S6-EH1P(12-16)K03-NV-YD-L-US

Solis Single Phase Low Voltage Energy Storage Inverters

Features:

- Generator-compatible to extend backup duration during grid power outage
- Multiple inverters can operate together to form a microgrid
- Supports dual backup ports for intelligent control of critical and non-critical loads
- 10 seconds of 200% overload capability
- Automatic switchover time is <4ms, providing seamless transitions from grid to backup
- Supports a maximum input current of 20A, making it ideal for all high-power PV modules of any brand
- Ensures excellent power supply stability, keeping the load unaffected by a weak grid or generator supply fluctuations
- The battery's DC side can handle a maximum charge/discharge current of up to 290A, allowing it to store more surplus energy generated by PV systems

Models:

S6-EH1P12K03-NV-YD-L-US

S6-EH1P14K03-NV-YD-L-US

S6-EH1P16K03-NV-YD-L-US



DATASHEET

S6-EH1P(12-16)K03-NV-YD-L-US

Models	12K	14K	16K
Input DC (PV side)			
Max. input voltage		550 V	
Rated voltage		380 V	
Start-up voltage		100 V	
MPPT voltage range		80-520 V	
Max. input current		40 A / 40 A / 40 A	
Max. short circuit current		50 A / 50 A / 50 A	
MPPT number/Max. input strings number		3/6	
Battery			
Battery type		Li-ion / Lead-acid	
Battery voltage range		40 - 60 V	
Max. charge / discharge current	250 A		290 A
Battery switch		Yes (400 A)	
Communication		CAN/RS485	
Number of batteries per inverter		See Battery Compatibility Sheet	
Output AC (Grid side)			
Rated output power	12 kW	14 kW	16 kW
Max. apparent output power	12 kVA	14 kVA	16 kVA
Rated output voltage		240 V	
Rated grid frequency		60 Hz	
Rated grid output current	50 A	58.3 A	66.7 A
Max. output current	50 A	58.3 A	66.7 A
THDi		<3%	
Input AC (Grid side)			
Input voltage range		211-264 V	
Max. input current		200 A	
Frequency range		58.8-61.2 Hz	
Output AC (Back-up)			
Rated output power	12 kW	14 kW	16 kW
Max. apparent output power		2 times of rated power, 10 s	
Back-up switch time		<10 ms	
Phase Power		240 V Split-Phase	
Rated output voltage (L1-L2)		240 V	
AC output voltage range		211-264 V	
Rated frequency		60 Hz	
Frequency range		55-65 Hz	
Rated output current	50 A	58.3 A	66.7 A
Max. output over current protection, 10 sec	109 A	127 A	145 A
Backup support configurations		Dedicated loads and whole-home	
Power factor		>0.99 (0.8 leading - 0.8 lagging)	
THDv (@linear load)		<3%	
Max. number of parallel		10	
Input Generator			
Max. input power		24 kW	
Max. input current		100 A	
Rated input frequency		60 Hz	
Efficiency			
Max. efficiency		97.6%	
CEC efficiency		97.2%	
Battery charged by PV Max. efficiency		98.5%	
Battery charged/discharged to AC Max. efficiency		97.0%	
Protection			
Ground fault monitoring		Yes	
Integrated AFCI		Yes	
DC reverse-polarity protection		Yes (PV only)	
Manual Inverter Bypass Switch		Yes	
Rapid Shutdown NEC 2017		Integrated SunSpec-certified Transmitter	
Compatible RSD Receivers		See MLRSD compatibility Sheet	
Protection class/Over voltage category		I/II	
General Data			
Dimensions (W*H*D)		18.3*30*11.1 in (464*763*282 mm)	
Weight		106.9 lbs (48.5 kg)	
Topology		Transformerless	
Operating ambient temperature range		-13 °F to 140 °F (-25°C to 60°C)	
Ingress protection		TYPE 4X	
Self-consumption (night)		<20 W	
Cooling concept		Intelligent redundant fan-cooling	
Mounting type		Wall Bracket	
Max. operation altitude		13120 ft (4000 m)	
Compliance		UL1741SB, IEEE1547-2018, UL1699B, UL1998, FCCPart15ClassB, California Rule21, NEC 690.12-2020, CAN/CSA C22.2107.1-1	
Features			
DC connection		Spring clamp terminals (PV port) / Spring clamp terminals (BAT port)	
AC connection		2.5 in. knockouts for conduit (x3) on the side and bottom; Spring clamp terminals	
Interface		LED + Bluetooth + APP	
Integrated Revenue Grade Meter		Optional	
MLRSD&Optimizer list		TBD	
Monitoring Platform		SolisCloud (modbus map and API sharing available upon request)	
Communication		RS485, Optional: Cellular, Wi-Fi, LAN	

S6-EH1P(3.8-11.4)K-H-US

Solis Single Phase High Voltage Energy Storage Inverters

Features:

- Up to 4 MPPTs and 16A of DC input current allows for PV array design flexibility
- Optimization, module-level monitoring, and rapid shutdown options available
- External RSD, EPO signal and BYPASS switch are available
- UL 9540 certified with multiple different battery brands (LG, BYD, Pylontech. ect)
- Bluetooth connection to mobile phone, make the setting and operation easier
- Automatic UPS switching and up to 170% (130A) 300ms surge power back up overload capacity support industrial air conditioner
- Intelligent AC coupling scheme, easily upgrade existing grid-connected systems
- Whole-home backup, generator integration, and load shading function with the new SolisHub
- Supports 1ph and 3ph flexible connection on both the Grid and Backup Port

Models:

S6-EH1P3.8K-H-US / S6-EH1P5K-H-US
 S6-EH1P7.6K-H-US / S6-EH1P9.9K-H-US
 S6-EH1P10K-H-US / S6-EH1P11.4K-H-US

Please consult the Ordering Guide for details on how to order the inverter with different accessories.



DATASHEET

S6-EH1P(3.8-11.4)K-H-US

Models	3.8K	5K	7.6K	9.9K	10K	11.4K
DC Input (PV)						
Max. input voltage	600 V					
Rated voltage	380 V					
Start-up voltage	80 V					
MPPT voltage range	80-520 V					
Max. input current per string	16 A					
Max. short circuit current per string	25.6 A					
Number of MPPTs/Number of strings per MPPT	2/1	3/1			4/1	
Energy Storage						
Battery type	Lithium-ion					
Battery voltage range	120-500 V					
Maximum charge/discharge current	25 A		50 A			
Battery communication	CAN/RS485					
Number of batteries per inverter	See Battery Compatibility Sheet					
AC Output (Grid)						
Rated output power	3.8 kW	5 kW	7.6 kW	9990 W	10 kW	11.4 kW
Max. apparent output power	3.8 kVA	5 kVA	7.6 kVA	9990 VA	10 kVA	11.4 kVA
Rated output voltage	240 V					
Rated frequency	60 Hz					
Rated output current	15.8 A	20.8 A	31.7 A	41.7 A	41.7 A	47.5 A
Max. output current	15.8 A	20.8 A	31.7 A	41.7 A	41.7 A	47.5 A
THDi	<3%					
AC Input (Grid)						
Input voltage range	211-264 V					
Max. input current	23.8 A	31.2 A	47.6 A	62.6 A	62.6 A	71.3 A
Frequency range	58.8-61.2 Hz					
AC Output (Backup and Off-grid)						
Rated output power	3.8 kW	5 kW	7.6 kW	9990 W	10 kW	11.4 kW
Max. apparent output power	6.1 kVA, 10 sec	8 kVA, 10 sec	12.2 kVA, 10 sec	16 kVA, 10 sec	16 kVA, 10 sec	18.2 kVA, 10 sec
Back-up switch time	<10 ms					
Phase Power	240 V Split-Phase					
Rated output voltage (L1-L2)	240 V					
AC output voltage range	211-264 V					
Rated grid frequency	60 Hz					
Frequency range	55-65 Hz					
Rated AC output current	15.8 A	20.8 A	31.7 A	41.7 A	41.7 A	47.5 A
Max. output overcurrent protection, 10 sec	25.4 A	33.3 A	50.7 A	66.7 A	66.7 A	76 A
Max. allowable phase imbalance	100%					
Backup support configurations	Whole-home and dedicated loads					
Power factor	>0.99 (0.8 leading - 0.8 lagging)					
THDv (@linear load)	<3%					
Efficiency						
PV Max. efficiency	97.0%				97.6%	
PV CEC efficiency	96.5%				97.0%	
Battery charged by PV Max. efficiency			98.5%			
Battery charged/discharged to AC Max. efficiency			97.0%			
Protection						
Ground fault detection	Yes					
Residual (leakage) current detection	Yes					
Integrated AFCI	Yes					
DC reverse-polarity protection	Yes (PV only)					
Manual inverter bypass switch	Yes					
Rapid Shutdown NEC 2017	Integrated SunSpec-certified Transmitter					
Compatible RSD Receivers	See MLRSD Compatibility Sheet					
Protection class/Over voltage category	I/II					
General Data						
Dimensions (W*H*D)	19.21*28.35*8.66 in (490*720*220 mm)			22.05*29.53*8.66 in (560*750*220 mm)		
Weight	52.43 lbs (23.78 kgs)			71.74 lbs (32.54 kgs)		
Topology	Transformerless					
Self-consumption (night)	< 20 W					
Operating ambient temperature range	-13 °F to 140 °F (-25°C to 60°C)					
Ingress protection	TYPE 4X					
Cooling method	Natural convection					
Mounting type	Wall Bracket					
Max. operation altitude	13,120 ft (4000 m)					
Compliance	UL 1741, UL 1741SB, IEEE1547-2018&2020, UL 1699B, UL 1998, California Rule 21, NEC 690.12-2020, CAN/CSA C22.2107.1-1, FCC Part 15 Class B					
Generator support	Yes; up to 25 kW (with a Solis Hub)					
Features						
DC connection	1 in. knockouts for conduit (x2) on the side and bottom; Spring clamp terminals					
AC connection	1.5 in. knockouts for conduit (x3) on the side and bottom; Spring clamp terminals					
Interface	LED indicator lights, Bluetooth/Mobile application					
Monitoring platform	SolisCloud (modbus map and API sharing available upon request)					
Revenue Grade Meter	Integrated ANSI C12.20 option					
Communication	RS485, Cellular, Wi-Fi, Optional: LAN					
Integrated RSD Transmitter Brands	See the MLRSD Compatibility Sheet					

Solis Hub-200A-US

Solis Hub Microgrid Interconnect Device (MID)

SolisHub is the Microgrid Interconnect Device (MID) for the PV, batteries, generator, grid, and home loads. SolisHub makes whole-home backup possible by allowing the integration of multiple inverters for greater PV power output and battery storage capacity. During grid outages, SolisHub automatically islands the home from the grid, allowing the Solis energy storage system to supply full power to the

entire home. It also provides generator integration, allowing for automatic whole-home backup when available PV and battery power are not sufficient to support all of the home loads. SolisHub communicates directly with Solis inverters and the battery system, allowing the homeowner to monitor and manage energy use and backup power through the SolisCloud.

Features:

- Up to 45.6kW for Whole-home backup, generator integration
- Load shedding function with remote control of loads when the grid is down
- Integrated autotransfer and manual disconnect switches for lower system cost
- Accepts standard circuit breakers making it easy to install and eliminates the need to upgrade the main service panel
- Allows up to 200 A of continuous backup power to the home
- Manual bypass switch for protection of the home loads

Models:

Solis Hub-200A-US

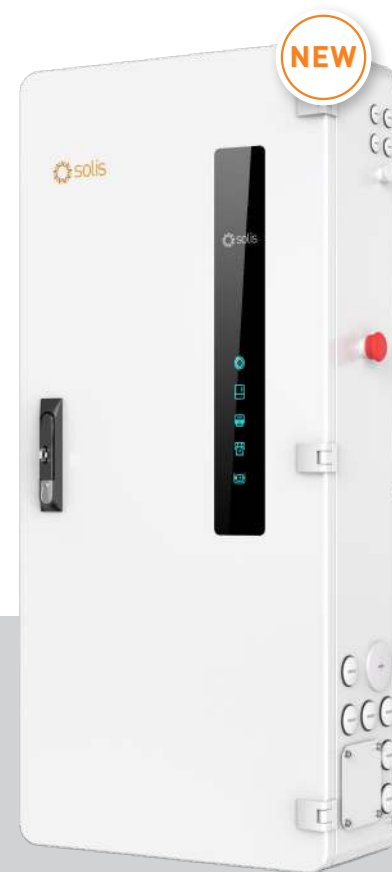

DATASHEET

Solis Hub-200A-US

Models	200A-US
AC Input from Inverters	
Max. input power	11.4 kW*3
Max. input number	3
Max. input current	60 A / 60 A / 60 A
Rated input voltage (L-L)	240 V
Input voltage range	204-276 V
Frequency	60 Hz
Frequency range	55-65 Hz
AC Input from Generator	
Max. input power	25 kW
Max. input current	105 A
Rated dry contact switch voltage	240 V / 24 V / 12 V
Rated dry contact switch current	5 A
2-wire start switch	Yes
AC Input from Grid	
Max. input current	200 A
Rated input voltage (L-L)	240 V
Rated input voltage (L-N)	120 V
Input voltage range	204-276 V
Frequency	60 Hz
Frequency range	55-65 Hz
Grid Disconnection Switchover Time	<180 ms
AC Output to main distribution panel	
Max. input number	4
Max. output current	60 A / 60 A / 60 A / 60 A
Rated output voltage (L-L)	240 V
Output voltage range (L-L)	204-276 V
Rated output voltage (L-N)	120 V
Output voltage range (L-N)	102-138 V
Frequency	60 Hz
Frequency range	55-65 Hz
AC Output to independent load	
Max. output current	200 A
Rated output voltage (L-L)	240 V
Output voltage range (L-L)	204-276 V
Rated output voltage (L-N)	120 V
Output voltage range (L-N)	102-138 V
Frequency	50 Hz / 60 Hz
Frequency range	45-55 Hz / 55-65 Hz
General Data	
Dimensions (W*H*D)	43.7*19.7*9.8 in (1100*500*250 mm)
Weight	70.9 lbs (32.1 kgs)
Operation temperature range	-13°F to 131°F (-25°C to 55°C)
Ingress protection	TYPE 3R
Cooling concept	Intelligent redundant fan-cooling
Max. operation altitude	13120 ft (4000 m)
Features	
AC connection (Grid side)	1 knockout for 2" conduit at side
AC connection (Inverter side)	3 knockout for 2" conduit at side
AC connection	6 knockout for 1.5" conduit at side
Communication	RS485, Dry contact

Residential Solar PV Solutions



Solis residential string inverters are cost-effective and efficient green power leaders, providing smarter green power solutions for your residential buildings. A variety of models and solutions meet the needs of modern homes.

The portfolio includes a wide range of models, providing the best home green power solutions based on your application scenarios and specific needs.

Solis Residential inverters are small and light, allowing for just one person to complete the installation. The overall design is sleek and modern, with low noise, particularly suitable for home installation without affecting people's daily activities.

Via online or App, you can connect to SolisCloud for intelligent energy management. Simple operation and convenient.

Solis residential solutions are technically advanced, flexible and simplify integration with digital home automation equipment and smart grids.

Inverter: Solis-1P(3.6-5)K-4G-US Solis-1P(6-10)K-4G-US

MLRSD and Optimizer: Cooperate with

Brand	Model	Product description (Standard)	
MLRSD	APS	RSD-S-PLC	Single input channel 1500V UL/1000V TUV, 1.2m cable, MC4
		RSD-D-15	Dual input channel 1500V UL/1000V TUV, 15A, 2.2m cable, MC4
	Tigo	TS4-A-F	Single input channel 1500VUL/1000VIEC, 15A, 1.2m Cable, MC4
		TS4-A-2F	Dual input channel 1500VUL/1000VIEC, 15A, 2.2m Cable, MC4
Optimizer	Tigo (Pending)	TS4-A-O	Single input channel 1500V UL / 1000V IEC, 15A, 0.12/1.2m cable, MC4

Noted: Contact manufacture for other connectors and cable length options.

Monitor: S1-W4G-ST/S2-WL-ST/S3-WiFi-ST (WiFi, Cellular, LAN solution)

Residential Solar PV Solution

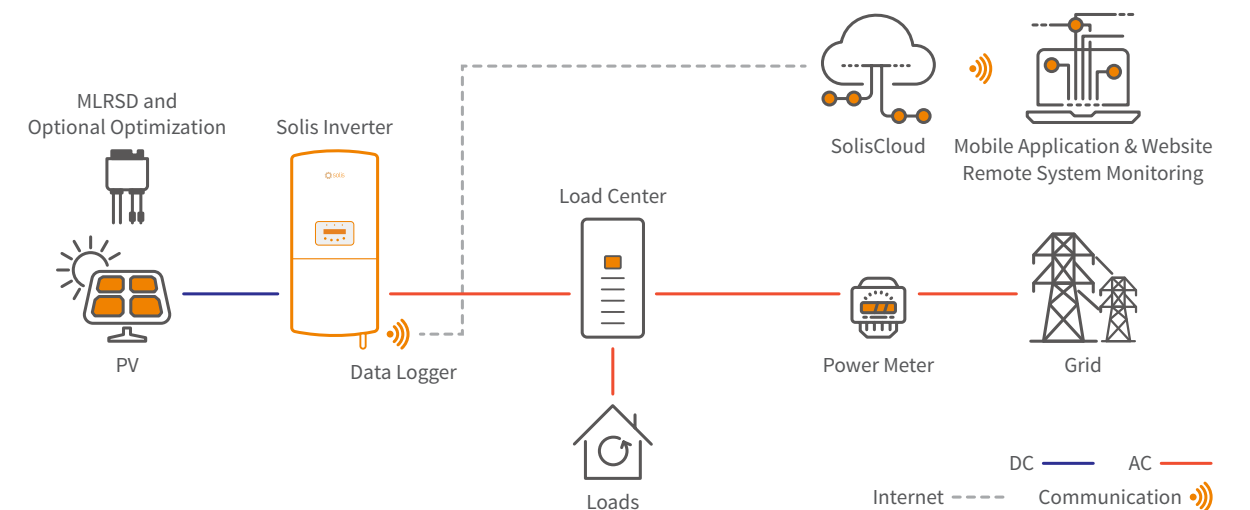

Solis-1P(3.6-5)K-4G-US

Solis Single Phase Grid-Tied Inverters

Features:

- Max. efficiency 97.7% (CEC efficiency 97.1%)
- String current up to 14A
- CA Rule 21 compliant and UL 1741 SB Certified
- Sunspec protocol with option cellular and WiFi
- Integrated module level rapid shutdown transmitter
- Support module level monitoring
- Optional Built-in Revenue Grade Meter, ANSI C12.20-2010 compliance
- Fast and dynamic MPPTs and industry-leading DC voltage range
- AFCI protection, proactively reduces fire risk
- 10 years standard warranty with extension options

Models:

Solis-1P3.6K-4G-US / Solis-1P5K-4G-US

Ordering: Solis-1P(3.6-5)K-4G-US-PLUS

- APST (APS MLRSD Transmitter)
Required for UL3741
- RSS (Tigo MLRSD Transmitter)
- CCA (Tigo CCA)



DATASHEET

Solis-1P(3.6-5)K-4G-US

Models	3.6K	5K
Input DC		
Max. input voltage	600 V	
Rated voltage	330 V	
Start-up voltage	120 V	
MPPT voltage range	90-520 V	
Max. input current	14 A / 14 A	
Max. short circuit current	22 A / 22 A	
MPPT number/Max. input strings number	2/2	
Output AC		
Rated output power	3.6 kW	5 kW
Max. apparent output power	3.6 kVA	5 kVA
Max. output power	3.6 kW	5 kW
Rated grid voltage	1Φ/PE, 240 V / 208 V	
Rated grid frequency	60 Hz	
Max. output current for 240V grid	15.0 A	20.8 A
Max. output current for 208V grid	17.3 A	24.0 A
Power factor	>0.99 (0.8 leading - 0.8 lagging)	
THDi	<3%	
Efficiency		
Max. efficiency	97.3%	97.7%
CEC efficiency	96.6%	97.1%
Protection		
DC reverse-polarity protection	Yes	
Ground fault monitoring	Yes	
Anti-islanding protection	Yes	
Integrated AFCI	Yes	
Integrated DC switch	Yes	
Rapid shutdown	Built-In APS or Tigo Transmitter	
Surge Protection	DC Type III / AC Type III	
Compliant MLRSD Products	TS4-A-F/2F/O, APSmart RSD-S / RSD-D	
General Data		
Dimensions (W*H*D)	13.9*31.9*6.5 in (353*810*165 mm)	
Weight	33.1 lbs (15 kgs)	
Topology	Transformerless	
Self-consumption (night)	<1 W	
Relative humidity	0-100%	
Operating ambient temperature range	-13°F to 140°F (-25°C to 60°C)	
Storage environment	-13°F to 176°F (-25°C to 80°C)	
Ingress protection	TYPE 4X	
Noise emission (typical)	<30 dB(A)	
Cooling concept	Natural convection	
Max. operation altitude	13,120 ft (4000 m)	
Compliance	UL1741SB, IEEE 1547-2018, UL1699B, UL1998, FCC Part15 ClassB, California Rule 21, HECO Rule 14H, NEC 690.12-2020, CAN/CSA C22.2107.1-1	
Features		
DC connection	1 knockout for 3/4" conduit at bottom, side and back, Screw clamp terminal	
AC connection	1 knockout for 3/4" conduit at bottom, side and back, OT terminal	
Display	LCD	
Communication	RS485, Optional: Cellular, Wi-Fi	

Solis-1P(6-10)K-4G-US

Solis Single Phase Grid-Tied Inverters

Features:

- Max. efficiency 97.8% (CEC efficiency 97.5%)
- String current up to 14A
- CA Rule 21 compliant and UL 1741 SB Certified
- Sunspec protocol with option cellular and WiFi
- Integrated module level rapid shutdown transmitter
- Support module level monitoring
- Optional Built-in Revenue Grade Meter, ANSI C12.20-2010 compliance
- Industry-leading 3 and 4 MPPT designs
- AFCI protection, proactively reduces fire risk
- 10 years standard warranty with extension options

Models:

Solis-1P6K-4G-US / Solis-1P7.6K-4G-US

Solis-1P10K-4G-US

Ordering: Solis-1P(6-10)K-4G-US-PLUS

- APST (APS MLRSD Transmitter)
Required for UL3741
- RSS (Tigo MLRSD Transmitter)
- CCA (Tigo CCA)



360° View

DATASHEET

Solis-1P(6-10)K-4G-US

Models	6K	7.6K	10K
Input DC			
Max. input voltage	600 V		
Rated voltage	330 V		
Start-up voltage	120 V		
MPPT voltage range	100 - 500 V		
Max. input current	14 A / 14 A / 14 A		14 A / 14 A / 14 A / 14 A
Max. short circuit current	22 A / 22 A / 22 A		22 A / 22 A / 22 A / 22 A
MPPT number/Max. input strings number	3/3		4/4
Output AC			
Rated output power	6 kW	7.6 kW	10 kW
Max. apparent output power	6 kVA	7.6 kVA	10 kVA
Max. output power	6 kW	7.6 kW	10 kW
Rated grid voltage	1Φ/PE, 240 V / 208 V		
Rated grid frequency	60 Hz		
Max. output current for 240V grid	25 A	31.7 A	41.7 A
Max. output current for 208V grid	28.8 A	36.5 A	43.3 A
Power factor	>0.99 (0.8 leading - 0.8 lagging)		
THDi	<3%		
Efficiency			
Max. efficiency	97.8%		
CEC efficiency	97.5%		
Protection			
DC reverse-polarity protection	Yes		
Ground fault monitoring	Yes		
Anti-islanding protection	Yes		
Integrated AFCI	Yes		
Integrated DC switch	Yes		
Rapid shutdown	Built-In APS or Tigo Transmitter		
Surge Protection	DC Type III / AC Type III		
Compliant MLRSD Products	TS4-A-F/2F/O, APSmart RSD-S / RSD-D		
General Data			
Dimensions (W*H*D)	13.1*28.8*9.8 in (333*732*249 mm)		
Weight	45.2 lbs (20.5 kgs)	45.6 lbs (20.7 kgs)	
Topology	Transformerless		
Self-consumption (night)	<1 W		
Relative humidity	0-100%		
Operating ambient temperature range	-13°F to 140°F (-25°C to 60°C)		
Storage environment	-13°F to 176°F (-25°C to 80°C)		
Ingress protection	TYPE 4X		
Noise emission (typical)	<30 dB(A)		
Cooling concept	Natural convection		
Max. operation altitude	13,120 ft (4000 m)		
Compliance	UL1741SB, IEEE 1547-2018, UL1699B, UL1998, FCC Part15 ClassB, California Rule 21, HECO Rule 14H, NEC 690.12-2020, CAN/CSA C22.2107.1-1		
Features			
DC connection	2 knockout for 1"conduit at bottom, 4 knockout for 3/4"conduit at side and back, Screw clamp terminal		
AC connection	2 knockout for 1"conduit at bottom, 4 knockout for 3/4"conduit at side and back, OT terminal		
Display	LCD		
Communication	RS485, Optional: Cellular, Wi-Fi		

Residential Power Plant Case Study



📍 Finland
⚡ 6.7kW 📦 S5-GR3P(3-20)K



📍 USA
⚡ 16kW 📦 Solis-(2.5-6)K-4G-US

Microgrid Project in Hebei Province

This microgrid project in Hebei province uses Solis-3P(12-25)K-5G and Solis-(25-50)K-5G inverters. Through the configuration of an energy storage system, the project adopts the mode of "Self-use, surplus electricity exported & sold back to the grid". This has realized consumption of new green energy to the region and delivers a stable income of about 1.6 million yuan annually.

In addition, the system is monitored in real-time via the SolisCloud platform which offers intelligent digital functions, online system control, along with accurate operation and maintenance. This in turn makes power station management more efficient, convenient and cost effective.

This project demonstrates the technological progress and expansion of the solar industry, accelerating the development of clean, low-carbon energy.



📍 Australia
⚡ 8.2kW 📦 Solis-1P(2.5-6)K-4G



📍 UK
⚡ 2.8kW 📦 S6-GR1P(2.5-6)K



📍 China
⚡ 2.7MW
📦 GCI-3P(12-25)K-5G



Commercial & Industrial Solar PV Solutions

Solis industrial and commercial string inverter product line is rich, the power range covers 25kW - 125kW, no matter how large your design and requirements are, we can rely on our flexible products to provide you with the best industry green power solutions.

Solis provides the most extensive industrial and commercial string inverter products on the market, and the products are sold well in various countries and regions in the world. They perform well in various harsh and complex environments, and are very stable and reliable.

Solis' C&I products are compatible with modularity and flexibility in program design. From the perspective of inverter performance improvement, we provide an ideal solution for simplifying system planning and design, including optimizing software algorithms, optimizing hardware port compatibility, etc., to improve system efficiency and reduce system investment costs.

The power range of Solis' C&I products covers a wide range, with a single power up to 125kW. High-efficiency and high-power-density inverters can reduce installation and maintenance workloads, lowering the LCOE and improve revenue.

Solis' C&I solutions are supplemented by a series of advanced digital services based on SolisCloud, simplifying the application difficulty of intelligent systems, and providing you with more complete, high-quality and efficient cloud intelligent operation and maintenance solutions.

Inverter: S6-GC(25-60)K-US S6-GC30K-LV-US S5-GC(75-125)K-US S5-GC60K-LV-US

MLRSD: Cooperate with

Brand	Model	Product description (Standard)
MLRSD	APS	RSD-D-20 Dual input channel 1500V UL/1000V TUV, 20A, 2.2m cable, MC4
	Tigo	TS4-A-F Single input 20A, 700W, 1500V UL / 1000V IEC, 0.62/1.2m Cable, MC4
		TS4-A-2F Dual input 20A, 1400W, 1500V UL / 1000V IEC, 1.2/1.3/2.4m Cable, MC4
	NEP	PVG-1-L Single input channel 1500V UL, 20A, 1.2m cable, MC4
		PVG-2-L Dual input channel 1500V UL, 20A, 2.2m cable, MC4

Noted: Contact manufacture for other connectors and cable length options.

Commercial & Industrial Solar PV Solution

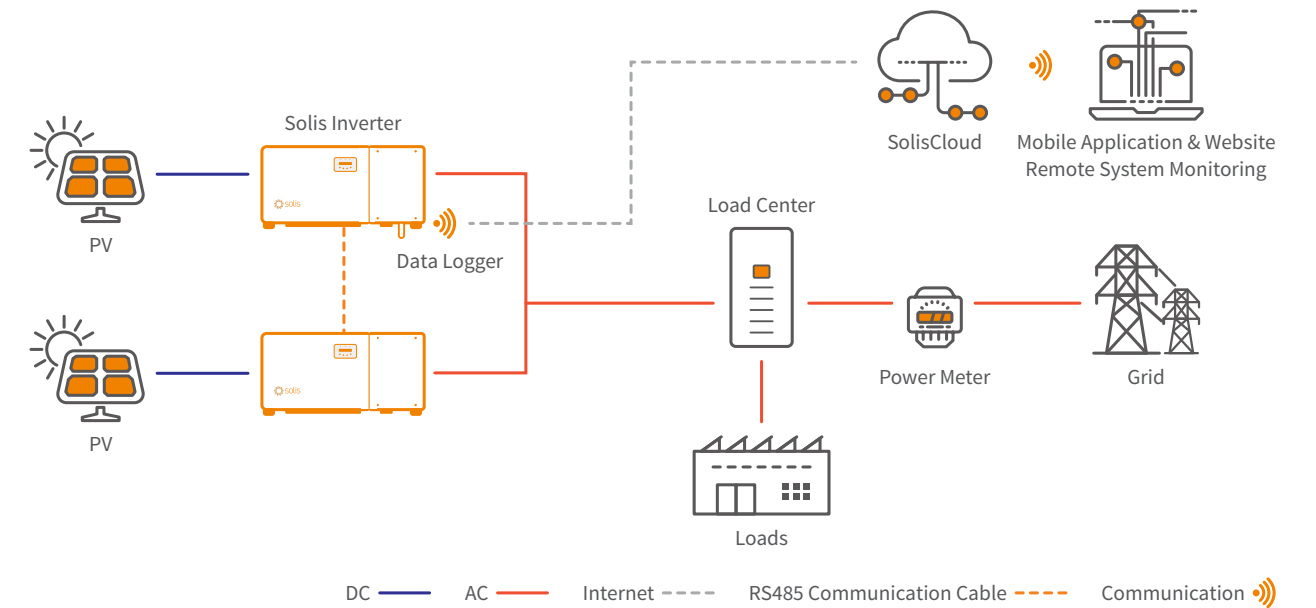

Monitor: S1-W4G-ST/S2-WL-ST/S3-WiFi-ST (WiFi, Cellular, LAN solution)

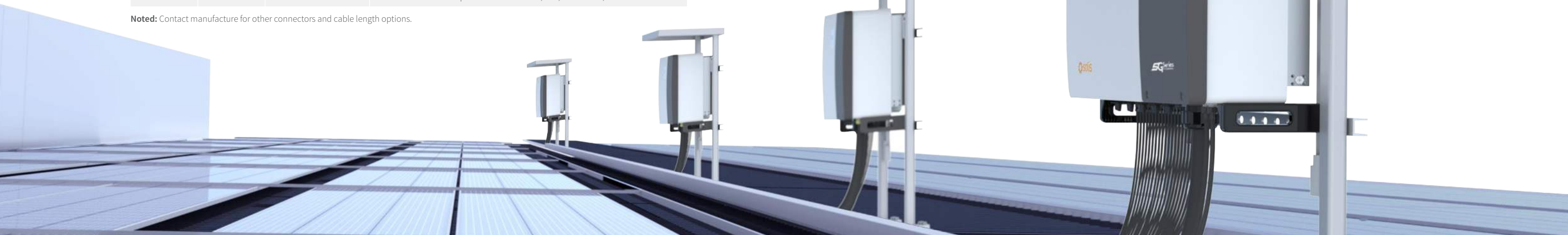

S6-GC(25-60)K-US

Solis Three Phase Grid-Tied Inverters

Efficient

- Max. efficiency 98.8% (CEC efficiency 98.3%)
- String current up to 20A
- 3/4 MPPT design, supports multiple orientation system design
- Night time PID recovery function, increases overall system yield (optional)
- Wide voltage range and low startup voltage

Smart

- Equipped with external power control interface, supporting zero output power control
- Intelligent string monitoring, smart I-V curve scan
- Supports RS485, Ethernet, WiFi, Cellular
- Scan to register on SolisCloud, supports remote upgrade and control

Models:

S6-GC25K-US / S6-GC33K-US
 S6-GC36K-US / S6-GC40K-US
 S6-GC50K-US / S6-GC60K-US

Ordering: S6-GC(25-60)K-US

- APST (APS MLRSD Transmitter)
- RSS (Tigo MLRSD Transmitter)
- NEPT (NEP MLRSD Transmitter)

Safe

- Type 4X, C5 Anti-Corrosion Level
- AFCI protection, proactively reduces fire risk
- Intelligent redundant fan-cooling
- Integrated module level rapid shutdown transmitter
- High quality components from globally recognized suppliers
- Integrated DC and AC disconnects

Economic

- > 1.5 DC/AC ratio
- Supports high power modules for lower installation costs
- Separable AC wiring box



DATASHEET

S6-GC(25-60)K-US

Models	25K	33K	36K	40K	50K	60K
Input DC						
Max. input voltage	1000 V					
Rated voltage	720 V					
Start-up voltage	180 V					
MPPT voltage range	180-1000 V					
Max. input current	3*40 A			4*40 A		
Max. short circuit current	3*63 A			4*63 A		
MPPT number/Max. input strings number	3/6			4/8		
Output AC						
Rated output power	25 kW	33 kW	36 kW	40 kW	50 kW	60 kW
Max. apparent output power	25 kVA	33 kVA	36 kVA	40 kVA	50 kVA	60 kVA
Max. output power	25 kW	33 kW	36 kW	40 kW	50 kW	60 kW
Rated grid voltage	3Φ/PE, 480 V					
Rated grid frequency	60 Hz					
Max. output current	30.1 A	39.7 A	43.3 A	48.1 A	60.1 A	72.2 A
Power factor	>0.99 (0.8 leading - 0.8 lagging)					
THDi	<3%					
Efficiency						
Max. efficiency	98.8%					
CEC efficiency	98.3%					
Protection						
DC reverse-polarity protection	Yes					
Short circuit protection	Yes					
Output over current protection	Yes					
Surge protection	DC Type II / AC Type II					
Grid monitoring	Yes					
Anti-islanding protection	Yes					
Temperature protection	Yes					
Strings monitoring	Yes					
I/V Curve scanning	Yes					
Integrated AFCI	Yes					
Integrated PID recovery	Optional					
Integrated DC switch	Yes					
Integrated AC switch	Yes					
General Data						
Dimensions (W*H*D)	30.9*21.6*12.6 in (784*549*320 mm)					
Weight	96.3 lbs (43.7 kgs)	105.4 lbs (47.8 kgs)	108.7 lbs (49.3 kgs)	110.5 lbs (50.1 kgs)		
Topology	Transformerless					
Self-consumption (night)	<1 W					
Relative humidity	0-100%					
Operating ambient temperature range	-13°F to 140°F (-25°C to 60°C)					
Ingress protection	TYPE 4X					
Noise emission (typical)	≤55 dB(A)					
Cooling concept	Natural convection					
Max. operation altitude	13,120 ft (4000 m)					
Compliance	UL1741SB, IEEE 1547-2018, UL1699B, UL1998, FCC Part15 ClassB, California Rule 21, Heco Rule 14H, NEC 690.12-2020, CAN/CSA C22.2107.1-1					
Features						
DC connection	MC4 connector					
AC connection	OT terminal (4 AWG to 3/0 AWG)					
Display	LCD					
Communication	Modbus RTU (Sunspec compliant), RS485, Optional: Cellular, Wi-Fi					

S6-GC30K-LV-US

Solis Three Phase Grid-Tied Inverters

Efficient

- Max. efficiency 97.7% (CEC efficiency 97.0%)
- String current up to 20A
- 3 MPPT design, supports multiple orientation system design
- Night time PID recovery function, increases overall system yield (optional)
- Wide voltage range and low startup voltage

Smart

- Equipped with external power control interface, supporting zero output power control
- Intelligent string monitoring, smart I-V curve scan
- Supports RS485, Ethernet, WiFi, Cellular
- Scan to register on SolisCloud, supports remote upgrade and control

Safe

- Type 4X, C5 Anti-Corrosion Level
- AFCI protection, proactively reduces fire risk
- Intelligent redundant fan-cooling
- Integrated module level rapid shutdown transmitter
- High quality components from globally recognized suppliers

Economic

- > 1.5 DC/AC ratio
- Supports high power modules for lower installation costs

Models:

S6-GC30K-LV-US

Ordering: S6-GC30K-LV-US

- APST (APS MLRSD Transmitter)
- RSS (Tigo MLRSD Transmitter)
- NEPT (NEP MLRSD Transmitter)



DATASHEET

S6-GC30K-LV-US

Models	30K
Input DC	
Max. input voltage	1000 V
Rated voltage	600 V
Start-up voltage	195 V
MPPT voltage range	180-1000 V
Max. input current	40 A / 40 A / 40 A
Max. short circuit current	63 A / 63 A / 63 A
MPPT number/Max. input strings number	3/6
Output AC	
Rated output power	30 kW
Max. apparent output power	30 kVA
Max. output power	30 kW
Rated grid voltage	3Φ/PE, 208 V
Rated grid frequency	60 Hz
Max. output current	83.3 A
Power factor	>0.99 (0.8 leading - 0.8 lagging)
THDi	<3%
Efficiency	
Max. efficiency	97.7%
CEC efficiency	97.0%
Protection	
DC reverse-polarity protection	Yes
Short circuit protection	Yes
Output over current protection	Yes
Surge protection	DC Type II / AC Type II
Grid monitoring	Yes
Anti-islanding protection	Yes
Temperature protection	Yes
Strings monitoring	Yes
I/V Curve scanning	Yes
Integrated AFCI	Yes
Integrated PID recovery	Optional
Integrated DC switch	Yes
Integrated AC switch	Yes
General Data	
Dimensions (W*H*D)	30.9*21.6*12.6 in (784*549*320 mm)
Weight	103.8 lbs (47.1 kgs)
Topology	Transformerless
Self-consumption (night)	<1 W
Relative humidity	0-100%
Operating ambient temperature range	-13°F to 140°F (-25°C to 60°C)
Ingress protection	TYPE 4X
Noise emission (typical)	≤55 dB(A)
Cooling concept	Natural convection
Max. operation altitude	13,120 ft (4000 m)
Compliance	UL1741SB, IEEE 1547-2018, UL1699B, UL1998, FCC Part15 ClassB, California Rule 21, Heco Rule 14H, NEC 690.12-2020, CAN/CSA C22.2107.1-1
Features	
DC connection	MC4 connector
AC connection	OT terminal (4 AWG to 3/0 AWG)
Display	LCD
Communication	Modbus RTU (Sunspec compliant), RS485, Optional: Cellular, Wi-Fi

S5-GC(75-125)K-US

Solis Three Phase Grid-Tied Inverters

Efficient

- 8/9/10 MPPTs, max. efficiency 98.8% (CEC efficiency 98.3%)
- > 1.5 DC/AC ratio
- String current up to 16A for higher capacity modules

Economic

- DC side supports "Y" connector

Safe

- Type 4X, C5 Anti-Corrosion Level
- UL 1741 SA and SB
- External signal control function
- Integrated nighttime PID recovery for optimal module performance
- AFCI protection, proactively reduces fire risk
- High quality components from globally recognized suppliers

Smart

- Intelligent string monitoring, smart I-V curve scan
- Remote firmware upgrade with simple operation⁽¹⁾

Models:

S5-GC75K-US / S5-GC80K-US
S5-GC90K-US / S5-GC100K-US
S5-GC125K-US

Ordering: S5-GC(75-125)K-US

- APST (APS MLRSD Transmitter)
- RSS (Tigo MLRSD Transmitter)
- NEPT (NEP MLRSD Transmitter)



360° View

(1) Requires the user to use Solis monitoring

DATASHEET

S5-GC(75-125)K-US

Models	75K	80K	90K	100K	125K
Input DC					
Max. input voltage	1000 V				
Rated voltage	600 V				720 V
Start-up voltage	195 V				
MPPT voltage range	180-1000 V				
Max. input current	8*32 A	9*32 A	10*32 A		
Max. short circuit current	8*50 A	9*50 A	10*50 A		
MPPT number/Max. input strings number	8/16	9/18	10/20		
Output AC					
Rated output power	75 kW	80 kW	90 kW	100 kW	125 kW
Max. apparent output power	75 kVA	80 kVA	90 kVA	100 kVA	125 kVA
Max. output power	75 kW	80 kW	90 kW	100 kW	125 kW
Rated grid voltage	3Φ/PE, 480 V				
Rated grid frequency	60 Hz				
Max. output current	90.2 A	96.2 A	108.3 A	120.3 A	150.4 A
Power Factor	>0.99 (0.8 leading - 0.8 lagging)				
THDi	<3%				
Efficiency					
Max. efficiency	98.7%			98.8%	
CEC efficiency	98.3%			98.2%	
Protection					
DC reverse-polarity protection	Yes				
Surge protection	DC Type II / AC Type II				
Ground fault monitoring	Yes				
Anti-islanding protection	Yes				
Strings monitoring	Yes				
I/V Curve scanning	Yes				
Rapid shutdown	Yes				
Integrated AFCI	Yes				
Integrated PID recovery	Yes				
AC switch	Yes				
General Data					
Dimensions (W*H*D)	41.9*22.3*13.6 in (1065*567*344.5 mm)				
Weight	187 lbs (85 kgs)				200 lbs (91 kgs)
Topology	Transformerless				
Self-consumption (night)	<2 W				
Relative humidity	0-100%				
Operating ambient temperature range	-22°F to 140°F (-30°C to +60°C)				
Storage environment	-40°F to 176°F (-40°C to 80°C)				
Ingress protection	TYPE 4X				
Cooling concept	Intelligent redundant fan-cooling				
Max. operation altitude	13,120 ft (4000 m)				
Compliance	UL1741SB, IEEE 1547-2018, UL1699B, UL1998, FCC Part15 ClassB, California Rule 21, Heco Rule 14H, NEC 690.12-2020, CAN/CSA C22.2107.1-1				
Features					
DC connection	MC4 connector				
AC connection	OT Terminal (max. 350 MCM)				
Display	LCD				
Communication	RS485, Optional: Wi-Fi, Cellular				

Ordering guidelines: Determine the basic model and add your desired features from above.
Ex: S5-GC75K-US-APST (Inverter with APS transmitter)

S5-GC60K-LV-US

Solis Three Phase Grid-Tied Inverters

Efficient

- 8 MPPTs, max. efficiency 98.5% (CEC efficiency 98.1%)
- > 1.5 DC/AC ratio
- String current up to 16A for higher capacity modules

Economic

- DC side supports "Y" connector

Safe

- Type 4X, C5 Anti-Corrosion Level
- UL 1741 SA and SB
- External signal control function
- Integrated nighttime PID recovery for optimal module performance
- AFCI protection, proactively reduces fire risk
- High quality components from globally recognized suppliers

Smart

- Intelligent string monitoring, smart I-V curve scan
- Remote firmware upgrade with simple operation⁽¹⁾

Models:

S5-GC60K-LV-US

Ordering: S5-GC60K-LV-US

- APST (APS MLRSD Transmitter)
- RSS (Tigo MLRSD Transmitter)
- NEPT (NEP MLRSD Transmitter)



360° View

(1) Requires the user to use Solis monitoring

DATASHEET

S5-GC60K-LV-US

Models	60K
Input DC	
Max. input voltage	1000 V
Rated voltage	450 V
Start-up voltage	195 V
MPPT voltage range	180-1000 V
Full Load MPPT voltage range	400-650 V
Max. input current	8*32 A
Max. short circuit current	8*50 A
MPPT number/Max. input strings number	8/16
Output AC	
Rated output power	60 kW
Max. apparent output power	60 kVA
Max. output power	60 kW
Rated grid voltage	3Φ/PE, 208 V
Rated grid frequency	60 Hz
Max. output current	166.5 A
Power factor	>0.99 (0.8 leading - 0.8 lagging)
THDi	<3%
Efficiency	
Max. efficiency	98.5%
CEC efficiency	98.1%
Protection	
DC reverse-polarity protection	Yes
Surge protection	DC Type II / AC Type II
Ground fault monitoring	Yes
Anti-islanding protection	Yes
Strings monitoring	Yes
I/V Curve scanning	Yes
Rapid shutdown	Yes
Integrated AFCI	Yes
Integrated PID recovery	Yes
AC switch	Yes
General Data	
Dimensions (W*H*D)	41.9*22.3*13.6 in (1065*567*344.5 mm)
Weight	200 lbs (91 kgs)
Topology	Transformerless
Self-consumption (night)	<2 W
Relative humidity	0-100%
Operating ambient temperature range	-22°F to 140°F (-30°C to +60°C)
Storage environment	-40°F to 176°F (-40°C to 80°C)
Ingress protection	TYPE 4X
Cooling concept	Intelligent redundant fan-cooling
Max. operation altitude	13,120 ft (4000 m)
Compliance	UL1741SB, IEEE 1547-2018, UL1699B, UL1998, FCC Part15 ClassB, California Rule 21, Heco Rule 14H, NEC 690.12-2020, CAN/CSA C22.2107.1-1
Features	
DC connection	MC4 connector
AC connection	OT Terminal (max. 350 MCM)
Display	LCD
Communication	RS485, Optional: Wi-Fi, Cellular

Ordering guidelines: Determine the basic model and add your desired features from above.
Ex: S5-GC60K-LV-US-APST (Inverter with APS transmitter)

C&I Power Plant Case Study



Ninghai Power Plant

- China
- 38MW
- Solis-(215-255)K-EHV-5G

Ninghai Power Plant transitions away from traditional thermal power to integrate solar power generation overcoming technical challenges along the way.

Ninghai Power is dedicated to the innovation of greener power through science and technology and has become a leader in Agrisolar development. As a pioneer in its industry the company has implemented a new energy park project which includes fishery-solar system, Agrisolar and floating solar systems, solar carport and



solar corridor as well as a more traditional solar rooftop. Over 8 different installation types have enabled more green energy to be installed in more areas - true "out of the box" thinking.

The solar plant now generates more than 300 billion kilowatts of green energy.



- India
- 1.12MW S5-GC(80-110)K



- Greece
- 100kW S5-GC(100-110)K

- UK
- 2MW
- Solis-(100-110)K-5G



- Netherlands
- 168.35kW Solis-(80-110)K-5G



- Philippines
- 270kW Solis-(25-30)K-LV

Utility Scale Solar PV Solutions



Solis has optimized and innovated around the entire process of utility solar PV solutions. Deeply integrated system design, digital management, and IoT technology effectively optimize the initial investment and future O&M costs of the power station increasing the power generation of the system and the rate of return on investment. Through the concept of "Efficient, safe, reliable, smart O&M, and system-friendly" we maximise the value for customers.

The 1500V high-power system solution can effectively reduce the number of equipment and cable consumption, reduce the initial investment cost, and facilitate installation and maintenance.

Solis utility PV solution has the characteristics of low LCOE. From the perspective of inverter performance improvement, it includes optimizing software algorithms and optimizing hardware port compatibility to improve system efficiency and reduce system investment costs.

Solis utility inverter has a large single power, up to 350kW. The high-efficiency and high-power-density inverter can reduce the workload of installation and maintenance, reduce costs and improve efficiency.

Solis utility PV solution is supplemented by a series of advanced digital services and intelligent monitoring equipment based on SolisCloud, simplifying the application difficulty of the intelligent system, and providing a more complete, high-quality and efficient cloud smart O&M solution.

Inverter: Solis-(125-255)K-EHV-5G-US S6-GU(250-350)K-EHV-US

MV Station: Solis-4200-MV

AC Combiner Box: Solis-AC Combiner

Utility Scale Solar PV Solution

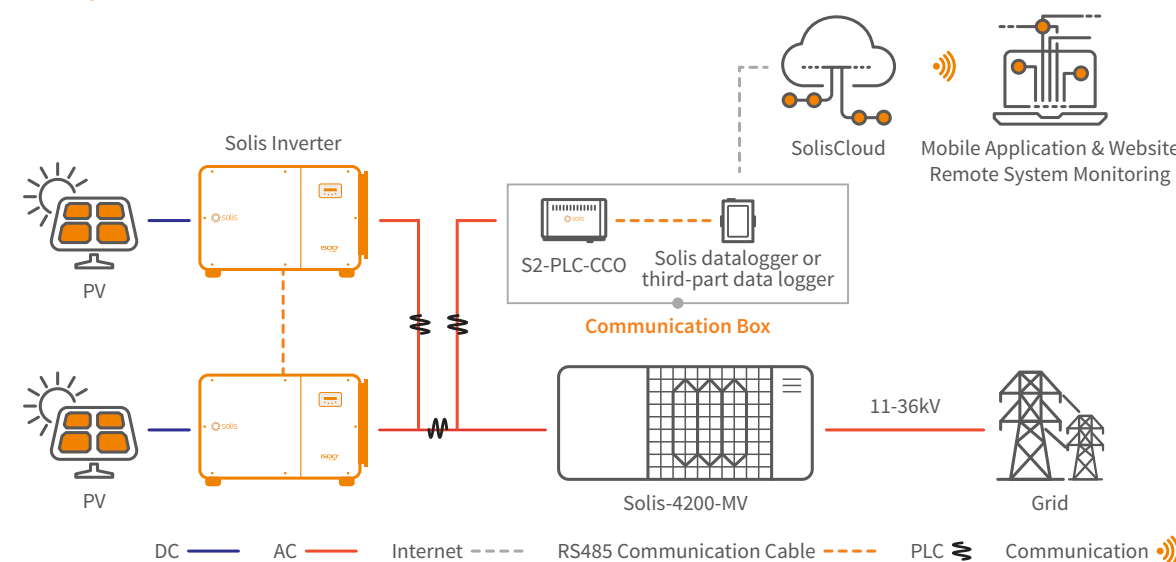

Solis-(125-255)K-EHV-5G-US-PLUS

Solis Three Phase Grid-Tied Inverters

Efficient

- 9/12 MPPTs, max. efficiency 99.0% (CEC efficiency 98.3%)
- > 1.5 DC/AC ratio
- High power tracking density 72MPPT/MW
- Compatible with 550W+ bifacial modules

Smart

- Intelligent string monitoring, smart I-V curve scan
- Remote firmware upgrade with simple operation⁽¹⁾

Safe

- Type 4X, C5 Anti-Corrosion Level
- External signal control function
- Integrated nighttime PID recovery for optimal module performance
- Fuse free design, safe and maintenance free
- AFCI protection, proactively reduces fire risk
- High quality components from globally recognized suppliers

Economic

- Power line communication (PLC) (optional)
- DC side supports "Y" connector
- Reserve DC energy storage access

Models:

- Solis-125K-EHV-5G-US-PLUS
- Solis-185K-EHV-5G-US-PLUS
- Solis-255K-EHV-5G-US-PLUS



(1) Requires the user to use Solis monitoring

DATASHEET

Solis-(125-255)K-EHV-5G-US-PLUS

Models	125K-PLUS	185K-PLUS	255K-PLUS
Input DC			
Max. input voltage	1500 V		
Rated voltage	950 V	1080 V	
Start-up voltage	500 V		
MPPT voltage range	480-1500 V		
Max. input current	9*30 A	12*30 A	
Max. short circuit current	9*50 A	12*50 A	
MPPT number/Max. input strings number	9/18	12/24	
Output AC			
Rated output power	125 kW	185 kW	255 kW
Max. apparent output power	137.5 kVA	185 kVA	255 kVA
Max. output power	137.5 kW	185 kW	255 kW
Rated grid voltage	3Φ/PE, 600 V		3Φ/PE, 800 V
Rated grid frequency	60 Hz		
Max. output current	132.3 A	178.0 A	184.0 A
Power factor	>0.99 (0.8 leading - 0.8 lagging)		
THDi	<3%		
Efficiency			
Max. efficiency	98.6%	98.7%	99.0%
CEC efficiency	98.3%		
Protection			
DC reverse-polarity protection	Yes		
Surge protection	DC Type II / AC Type II		
Ground fault monitoring	Yes		
Anti-islanding protection	Yes		
Strings monitoring	Yes		
Integrated AFCI	Yes		
Integrated PID recovery	Yes		
I/V Curve scanning	Yes		
General Data			
Dimensions (W*H*D)	46.1*30.3*15.1 in (1170*770*384 mm)		
Weight	240 lbs (109 kgs)	249.0 lbs (113 kgs)	
Topology	Transformerless		
Self-consumption (night)	<2 W		
Relative humidity	0-100%		
Operating ambient temperature range	-22°F to 140°F (-30°C to +60°C)		
Storage environment	-40°F to 176°F (-40°C to 80°C)		
Ingress protection	TYPE 4X		
Cooling concept	Intelligent redundant fan-cooling		
Max. operation altitude	13,120 ft (4000 m)		
Compliance	UL 1741SB, UL 1998, UL1699B, IEEE 1547-2018, FCC Part 15 (Class A & B), CAN/CSA C22.2 107.1-1, California Rule 21		
Features			
DC connection	MC4 connector		
AC connection	OT terminal (750 MCM)		
Display	LCD		
Communication	RS485, Optional: PLC		

S6-GU(250-350)K-EHV-US

Solis Three Phase Grid-Tied Inverters

Efficient

- 12/16 MPPTs, max. efficiency 99.0%
- > 150% DC/AC ratio
- Lower starting voltage, longer power generation time
- Wide MPPT current design, compatible with 182 and 210 series bifacial modules

Smart

- Night SVG function
- Intelligent string monitoring. Smart I-V curve scan
- Remote firmware upgrade with simple operation

Safe

- Type 4X, C5 Anti-Corrosion Level
- Built-in PID recovery for better module performance
- Fuse free design, safe and maintenance free

Economic

- Power line communication (PLC) (optional)
- Integrated tracking bracket power supply interface

Models:

- S6-GU250K-EHV-US-M12
- S6-GU300K-EHV-US-M12
- S6-GU350K-EHV-US-M12
- S6-GU350K-EHV-US-M16



DATASHEET

S6-GU(250-350)K-EHV-US

Models	250K-M12	300K-M12	350K-M12	350K-M16
Input DC				
Max. input voltage	1500 V			
Rated voltage	1080 V			
Start-up voltage	500 V			
MPPT voltage range	480-1500 V			
Max. input current	12*40 A			16*30 A
Max. short circuit current	12*70 A			16*60 A
MPPT number/Max. input strings number	12/12			16/16
Output AC				
Rated output power	250 kW	300 kW	350 kW	
Max. apparent output power	250 kVA	300 kVA	350 kVA	
Max. output power	250 kW	300 kW	350 kW	
Rated grid voltage	3Φ/PE, 600 V	Φ/PE, 690 V	3Φ/PE, 800 V	
Rated grid frequency	60 Hz			
Max. output current	240.6 A	251.0 A	252.6 A	
Power factor	>0.99 (0.8 leading - 0.8 lagging)			
THDi	<3%			
Efficiency				
Max. efficiency	99.0%			
CEC efficiency	98.5%			
Protection				
DC reverse-polarity protection	Yes			
Anti-islanding protection	Yes			
Strings monitoring	Yes			
I/V Curve scanning	Yes			
Integrated AFCI	Yes			
Integrated PID recovery	Yes			
General Data				
Dimensions (W*H*D)	45.9*37.2*16.3 in (1227*995.8*463.8 mm)			
Weight	297 lbs (135 kgs)			
Topology	Transformerless			
Self-consumption (night)	<3 W			
Operating ambient temperature range	-22°F to 140°F (-30°C to +60°C)			
Relative humidity	-40°F to 176°F (-40°C to 80°C)			
Ingress protection	TYPE 4X			
Cooling concept	Intelligent redundant fan-cooling			
Max. operation altitude	13,120 ft (4000 m)			
Compliance	UL 1741, UL 1998, UL 1699B, IEEE 1547, FCC Part 15 (Class A & B), CAN/CSA C22.2 107.1-1, California Rule 21 Phaes II & III			
Features				
DC connection	MC4 connector			
AC connection	OT terminal (1000 MCM)			
Display	LED, Bluetooth + APP			
Communication	RS485, Optional: PLC			

Solis-4200-MV

Solis MV Station

For 1500 V string inverter Solis (125-255)K and (250-350)K

Integrated delivery

- Mainstream 4.2MW subarray, widely used globally
- 20 foot standard container delivery, easy to transport

Convenient installation

- A complete solution, from inverter to main step-up transformer
- When the MV station is lifted to the foundation, only LV and MV cables need to be connected

Reliable products

- LV busbar, transformer and MV cabinet be placed independently
- Adopt international first-line brand equipment with reliable quality

Easy O&M

- Full frontal maintenance design
- Modular design of MV equipment, easy to replace



Circuit diagram

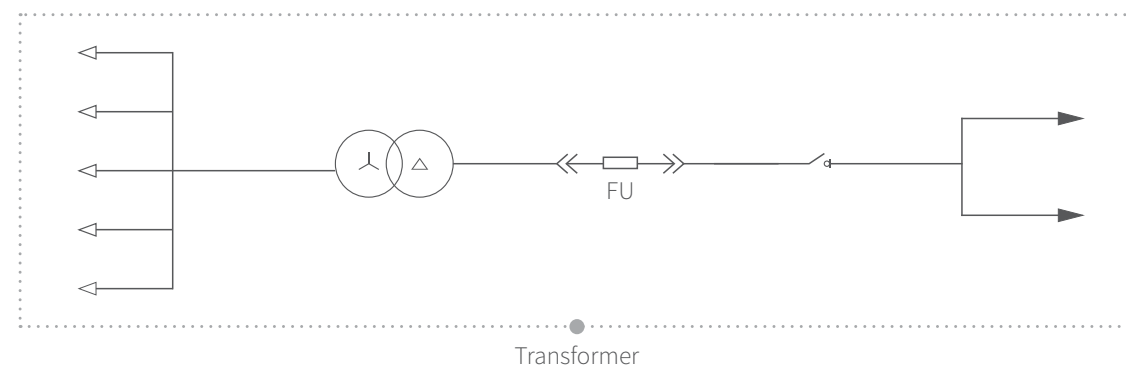

DATASHEET

Solis-4200-MV

Models	Solis-4200-MV
LV panel	
MCCB specification	250 A / 800 Vac / 3P, 18 pcs
ACB specification	4000 A / 800 Vac / 3P, 1 pcs
Connection form with transformer	Copper busbar
Transformer	
Transformer type	Oil immersed
Rated output power	4200 kVA @ 40°C
Max. output power	4620 kVA @ 30°C 3h
LV/MV voltage	0.8 kV / 34.5 kV
Max. input current	3312 A
Tapping on HV	±2*2.5%
Vector group	Dy11
Frequency	60 Hz
Cooling type	ONAN
Impedance	7%
Oil type	Mineral oil (plant oil optional)
Winding material	Al / Al (Optional: Cu / Cu)
Insulation class	A
Protection	
LV surge protection	AC type I+II
AC input protection	Circuit breaker
AC MV output protection	Load switch + Fuse
Transformer protection	Oil-temperature, oil-level, oil-pressure
Fire protection	emergency lighting
General Data	
Dimensions (W*H*D)	6058*2896*2438 mm
Approximate weight	20 T
Operating ambient temperature range	-25 to +60°C
Max. operation altitude	1000 m (standard)
Auxiliary power supply	5 kVA / 240 V (Optional: max. 30kVA)
Degree of protection	IP54
Allowable relative humidity range	0-95%
Communication	RS485, Ethernet, Optical fiber
Compliance	IEC 60076, IEEE C57

Solis-AC Combiner

Solis AC Combiner Box

For 1500 V string inverter Solis 255K and 350K

Features:

- Strong safety, high economy, standard overcurrent protection
- Protection class NEMA Type 3R, which meets the requirements of outdoor installation
- Small size, light weight, attached installation, reduce engineering construction costs
- Easy connection, simple operation

Models:

- Solis-AC Combiner-800V/1000A
- Solis-AC Combiner-800V/800A
- Solis-AC Combiner-800V/630A



DATASHEET

Solis-AC Combiner

Models	800V/1000A	800V/800A	800V/630A
Input			
Number of AC input circuits	3, 4	3	2
OCPD	Fuse		
Rated input voltage	800 V		
Rated input current	3*251 A, 4*185 A	3*185 A	2*251 A
Input conductor size	3*(300-750kcmil CU/AL)		
Input conduit knockout size	Removable bottom plate		
Output			
Rated output current	753 A	555 A	502 A
Output conductor size	3*(2*600-1000kcmil CU/AL)		
Output conduit knockout size	Removable bottom plate		
Short circuit interrupt capacity	65 kA		
Output fuse rating	1000 A	800 A	630 A
Mechanical			
Dimensions (W*H*D)	48.2*37*15 in (1225*940*380 mm)		
Weight	154.3 lbs (70 kgs)		
Equipment grounding	Yes		
Padlockable enclosure (LOTO)	Yes		
Breather vent	Yes		
Grounding busbar	No		
Environment			
Degree of protection	NEMA Type 3R		
Operating ambient temperature range	-22°F to 140°F / -30°C to +60°C (derating from +104°F / +40°C)		
Relative humidity	0-100%		
Max. operation altitude	9842 ft / 3000 m (no derating); 13,120 ft / 4000 m (max)		
Safety			
Compliance	UL1741		

Utility-scale Plant Case Study



📍 Mexico
⚡ 20MW 📦 Solis-20K-HV



📍 Poland
⚡ 10MW 📦 Solis-125K-EHV-5G



📍 China
⚡ 1GW 📦 Solis-(215-255)K-EHV-5G



📍 India
⚡ 2MW 📦 Solis-(100-110)K



📍 China
⚡ 300MW 📦 Solis-(215-255)K-EHV-5G

Tidal-Flat 300MW Utility Scale Solar PV Plant

After the project is put into operation, the generating capacity is estimated to be 400,000,000 kWh/ year and delivers a reduction of 350, 000 tons of CO₂, 12,000 tons of SO₂, and 110,000 tons of Carbon dust. Solis commercial scale string inverters boast an abundance of technological features which can adapt to a variety of environments. We look forward to seeing more applications utilizing Solis inverters. We are committed to our mission - Developing Technology to Power the World with Clean Energy.

Export Power Management Solutions



In some countries, local regulations limit the amount of PV power that can be exported to the grid or allow no export. Solis offers two export limitation solutions for single and multiple inverters system.

Export Power Management Solutions - Single-inverter System

In a single-inverter system, the export limitation is integrated into the inverter firmware. Use a meter or a CT to measure the output of the system, then to adjust PV power production.

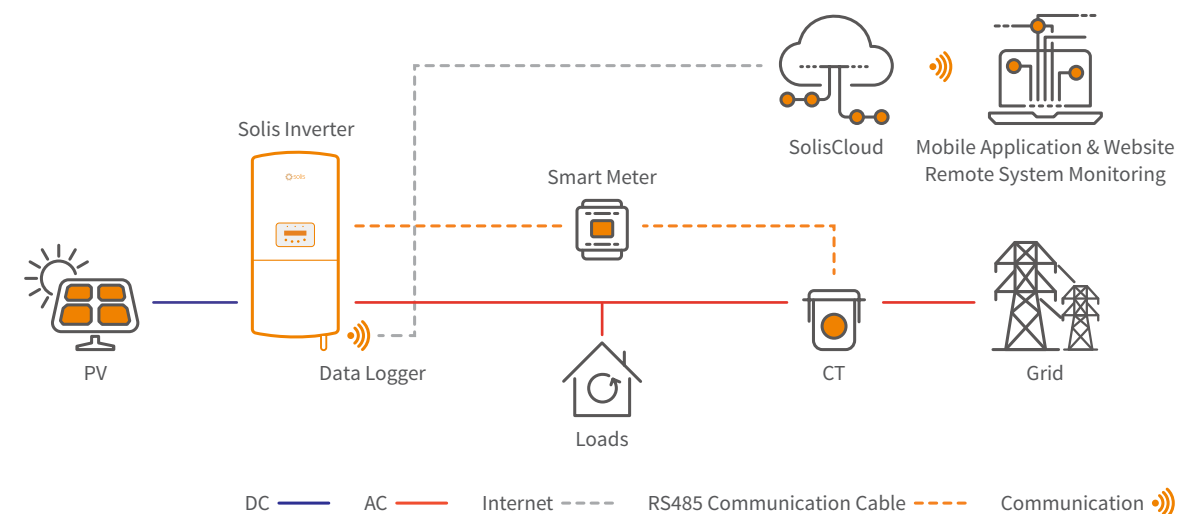

Export Power Management Solution - Multi-inverter System

In a multi-inverter system, the export limitation is integrated into the EPM (Export Power Manager) firmware. The EPM will monitor and control the backflow power from the inverter to the grid thus providing export power control of inverters.

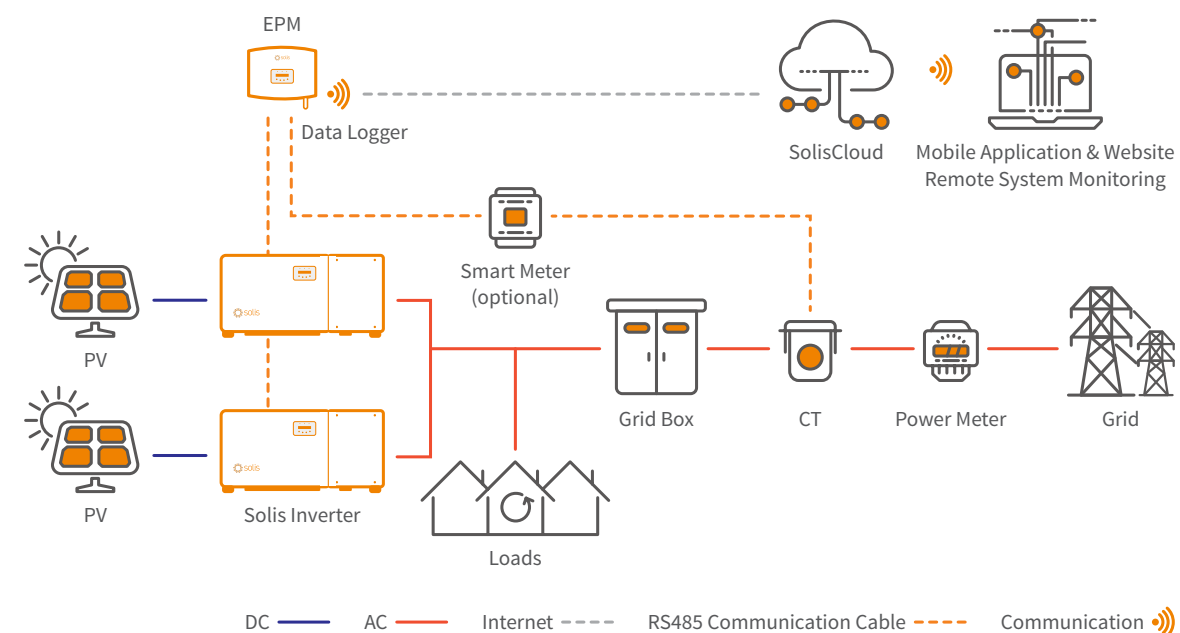

Solis-EPM3-5G-PRO

Solis Export Power Manager

Smart & strong

- Simultaneous control of 20 X Solis inverters
- Realizing reactive compensation of the system

Saving & high precision

- Simultaneously monitor the operating data of the 20 X Solis inverter, saving the cost of the monitoring system
- The control accuracy is up to 1%, which improves the system's spontaneous use rate

Friendly & compatible

- Supports simultaneous access of Solis inverters with different powers
- Monitor power generation and load consumption at all times

Models:

Solis-EPM3-5G-PRO



DATASHEET

Solis-EPM3-5G-PRO

Models	Solis-EPM3-5G-PRO
Input AC	
Rated voltage	1Φ/PE, 240 V; 3Φ/PE, 480 V
Input voltage range	100 ~ 300 V (L-N); 175 ~ 494 V (L-L)
Input frequency range	45-65 Hz
Communication	
Inverter communication	Modbus
Communication with inverter	RS485 (Wired)
Max. communication inverter numbers	20 pcs
Monitoring	WiFi/4G/LAN Stick (Optional)
General Data	
Operating ambient temperature range	-13 °F to 140 °F (-25°C to 60°C)
Relative humidity	5%-95%
Max. operation altitude	2000 m
Ingress protection	Type 4X
Pollution degree	PD2 (Inside), PD3 (Outside)
Overvoltage category	III
Self-consumption	<6 W
Dimensions (W*H*D)	364*276*114 mm
Weight	2.1 kg (without CT, Meter)
AC connection	Quick connection terminal
Display	LCD
Smart meter	Split phase: AGF-AE-D; Three phase: ADL3000-E-B
CT connection	Plug terminal
CT specification	Split phase: Standard(200/40 mA); Three phase: Optional(Secondary current is 5 A)
Power control accuracy	1%Pn
Features	
Failsafe function	Yes
Remote upgrade	Yes
Control time	5 s

Specification	Dimensions (mm)			Hole size (mm)		Ratio
	W	H	D	a	e	
CT-30×20-100 A	90	114	40	22	32	100:5 A
CT-60×40-300 A	114	140	36	42	62	300:5 A
CT-80×40-600 A	122	162	40	42	82	600:5 A
CT-80×40-1000 A	122	162	40	42	82	1000:5 A
CT-160×80-2000 A	184	254	52	82	162	2000:5 A
CT-160×80-3000 A	184	254	52	82	162	3000:5 A

SolisCloud: Intelligent Solar Energy System Monitoring

The SolisCloud intelligent monitoring system includes hardware and software products and is a comprehensive energy management solution. Hardware products, including data stick, data box, EPM and PLC, etc; transmit to SolisCloud online energy management platform. Real-time monitoring, visualized management and remote O & M of residential, C&I and utility scale solar PV plants.

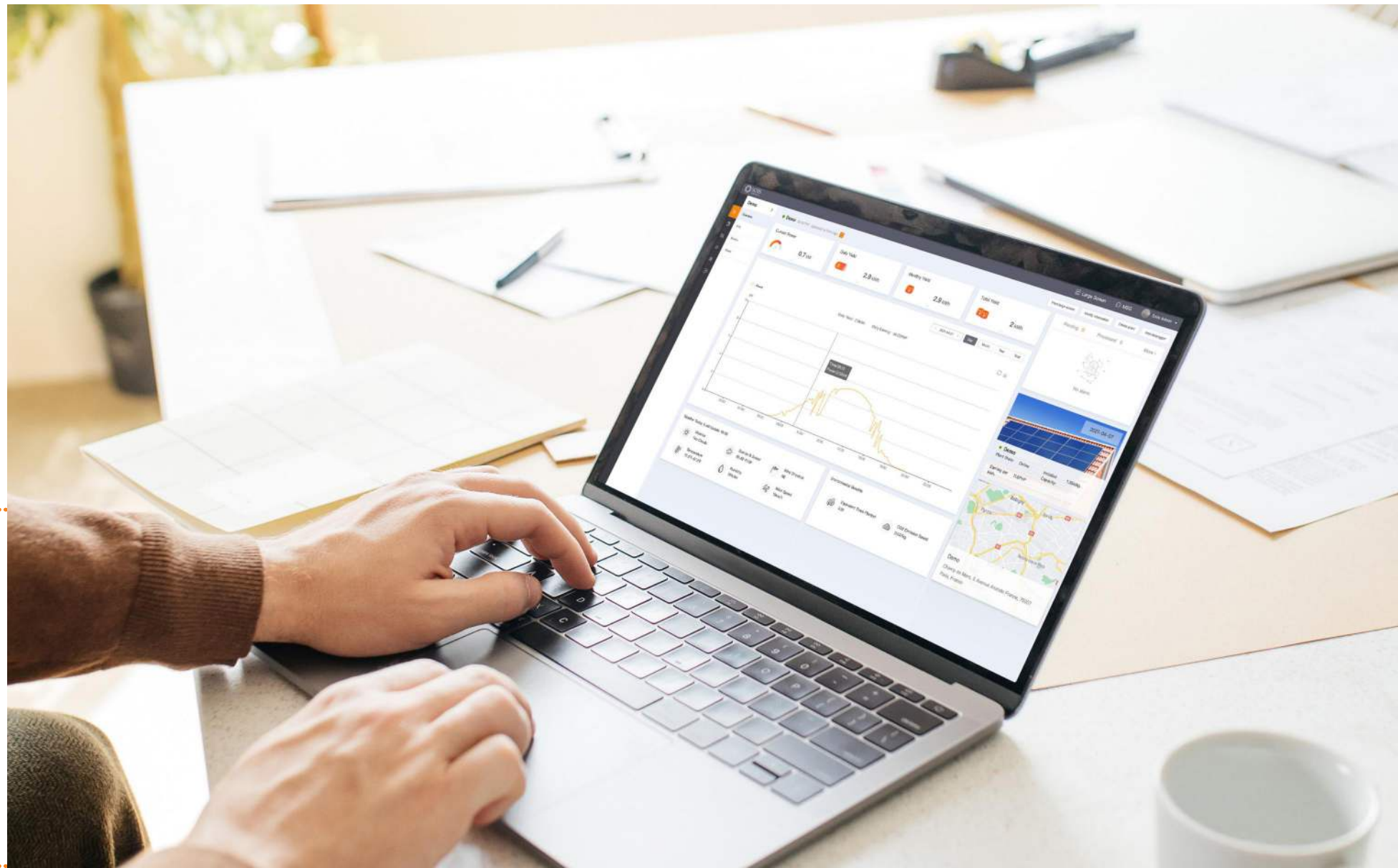

S2-WL-ST



S2-WL-ST (4 Pin)

S2-WL-ST (USB)

Wi-Fi/LAN stick, ≤10 inverters

S3-WiFi-ST



S3-WiFi-ST

Wi-Fi stick, ≤10 inverters
4 pin connection

S4-WiFi-ST



S4-WiFi-ST

Wi-Fi stick, ≤10 inverters
USB connection

S1-W4G-ST



S1-W4G-ST (4 Pin)

S1-W4G-ST (USB)

Wi-Fi/Cellular stick, ≤10 inverters

S2-PLC-CCO



S2-PLC-CCO

SolisCloud

New generation Solis PV monitoring platform

SolisCloud is the new generation of intelligent PV system monitoring. This new monitoring platform will empower you like never before. You will have full control of your system whenever and wherever you are. You will benefit from upgraded accurate fault alarm messaging that is adjustable to notify you within hours that fit meet your needs.

For simple O&M the new platform features a full size display of all your installations with real-time data. You will have an intelligent alarm system that gives recommendations to quickly repair your field faults. In depth analysis tools allow you to understand the overall health of your system. IV curve scanning can be done easily and quickly on your whole system. A live power flow display gives visibility of both standard solar systems as well as storage systems. Most importantly you will have complete control of your systems and be able to monitor and adapt anything when and how you want.



Advanced Cloud Platform

- Connecting with multiple types of devices seamlessly: Inverters, export power managers, weather stations, etc.

Efficient O & M

- Smart I-V curve scan, system health report, string-level fault finding

Multiple Plant Management

- Manage multiple types of systems across residential, commercial and utility scale plants. Enables multiple team management across different sectors



Full Screen Display Mode

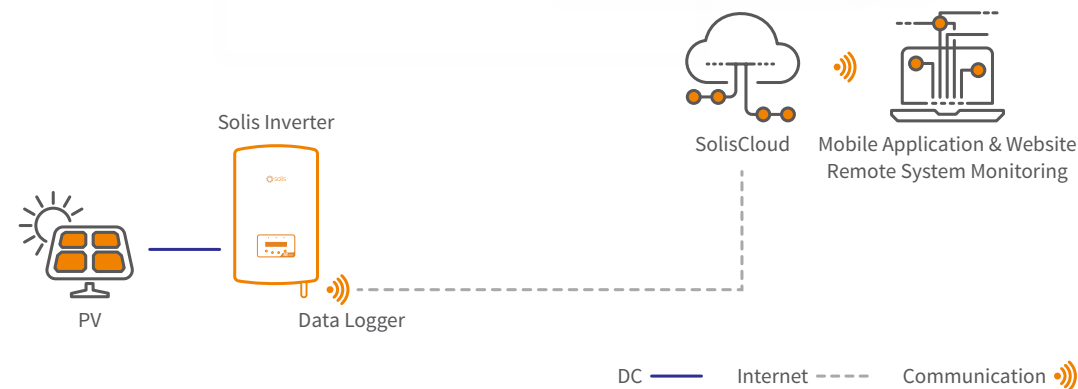

- Clear and concise display of system performance and benefits including carbon emissions saved and equivalent trees planted as well as showing system yield & earnings

Intelligent Monitoring Solution - SolisCloud







Download the App

Search for "Solis"

FOLLOW US

The Full Series of Operation Videos Will be available on **Youtube**

Accessories available:

- S2-WL-ST S1-W4G-ST
- S3-WiFi-ST S2-PLC-CCO
- S4-WiFi-ST

S2-WL-ST

Solis Wi-Fi&LAN Data Logger

Models: S2-WL-ST (4 Pin) and S2-WL-ST (USB)

Description:

Up to 10 inverters can be connected to 1 data logger. The logger connects with the local router through Wi-Fi or LAN and transmits data to SolisCloud. SolisCloud, the Solis monitoring platform, allows for remote system monitoring and control. The data is clear and detailed, making it easy to monitor and troubleshoot from anywhere anytime.

Features:

- Supports WiFi and LAN communication
- Simple plug-and play installation makes commissioning quick and easy
- Sends alarm notifications through text and email
- Intuitive LED indicator lights displays the operating status
- One button for instant data transmission and device configuration
- Support Bluetooth nearby connection and debugging
- One-key assignment of inverter address, efficient and labor-saving



S2-WL-ST (4 Pin)



S2-WL-ST (USB)

Intelligent Monitoring Solution - S2-WL-ST

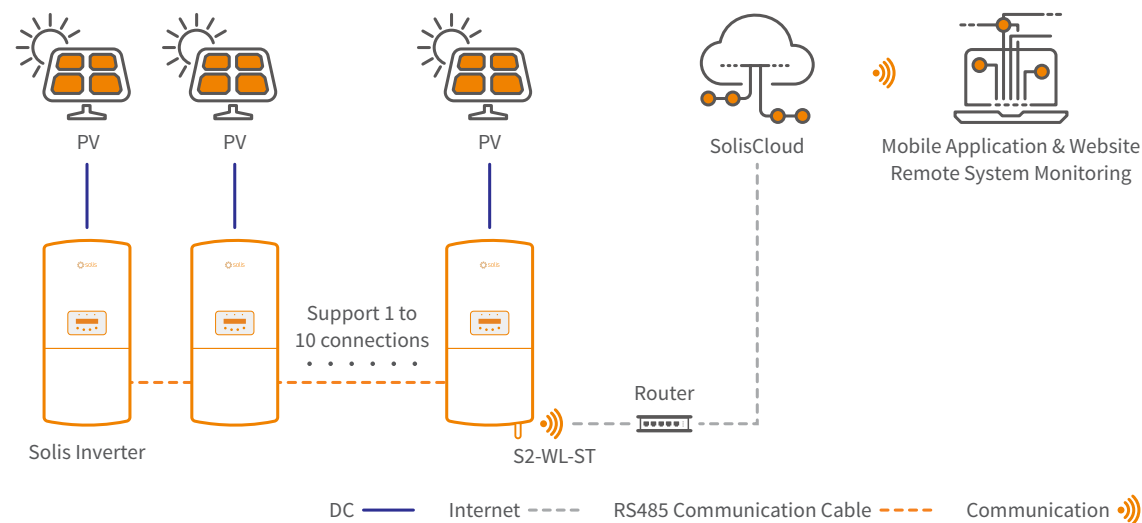

DATASHEET

S2-WL-ST

Models	S2-WL-ST (4 Pin)	S2-WL-ST (USB)
Communication		
Supported device type	All Solis models except for Solis S6 inverter	Solis S6 inverter
Number of connected inverters ⁽¹⁾	≤10	
Data collection intervals	5 minutes	
Status indicator	3 LED Indicator Lights	
Inverter connection interface	External 4-Pin Port	External USB Port
Ethernet communication	Number of routes × 1, 10 / 100Mbps adaptive, communication distance ≤ 100m	
Wireless communication	802.11b/g/n (2.4G) ⁽²⁾	
Near end communication	BLE4.2	
Configuration method	Mobile Application and Website	
Electrical		
Operating voltage	DC 5V (+/-5%)	
Operating power consumption	≤2 W	
Environment		
Operating ambient temperature range	-22°F to 149°F (-30 to +65°C)	
Operating humidity	5%-95%, Relative humidity, non-condensing	
Storage temperature	-40°F to 158°F (-40 to +70°C)	
Storage humidity	< 40%	
Max. operation altitude	13,123 ft. (4,000 m)	
Protection degree	NEMA 4X	
Mechanical		
Dimensions (L*W*H)	5.7*2*1.6 in (145*50*41 mm)	5.1*2*1.6 in (130*50*41 mm)
Installation method	Externally Insert + Twist Lock	Externally Insert + Tab Lock
Weight	0.22 lb(100 g)	0.2 lb (90 g)
Others		
Certification	CE, FCC	

(1) Inverters must first be daisy-chained with RS485. (2) 5 GHz Wi-Fi networks are not supported.

S3-WiFi-ST

Solis Wi-Fi Data Logger

Description:

Up to 10 inverters can be connected to 1 data logger. The logger connects with the local Wi-Fi network and transmits data wirelessly to SolisCloud. SolisCloud, the Solis monitoring platform, allows for remote system monitoring and control. The data is clear and detailed, making it easy to monitor and troubleshoot from anywhere anytime.

Features:

- Sends alarm notifications through text and email
- Intuitive LED indicator lights displays the operating status
- Simple plug-and play installation makes commissioning quick and easy
- One button for instant data transmission and device configuration



S3-WiFi-ST

Intelligent Monitoring Solution - S3-WiFi-ST

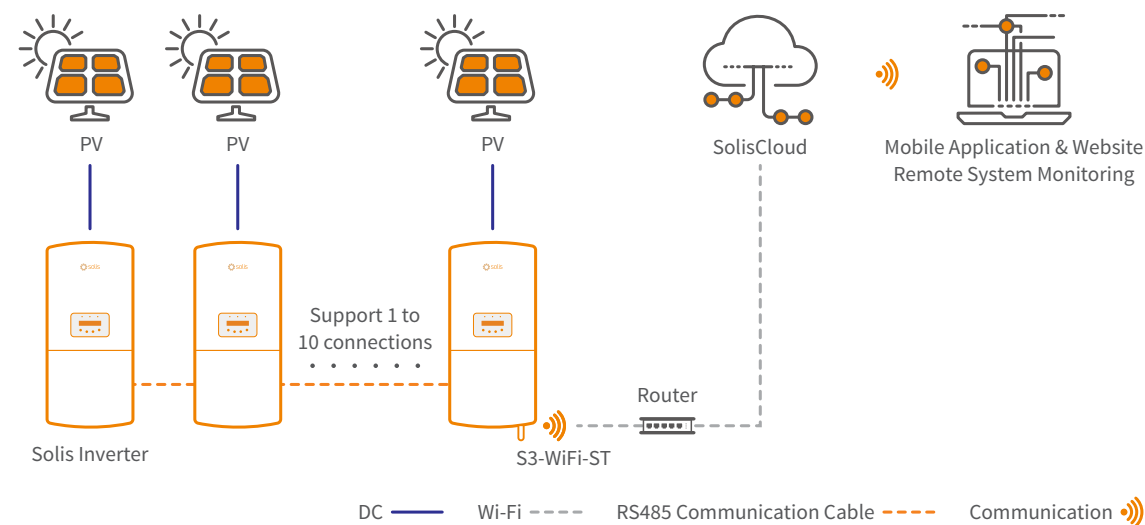

DATASHEET

S3-WiFi-ST

Models	S3-WiFi-ST
Communication	
Supported device type	All Solis models except for Solis S6 inverter
Number of connected inverters ⁽¹⁾	≤10
Data collection intervals	5 minutes
Status indicator	3 LED Indicator Lights
Inverter connection interface	External 4-Pin Port
Wireless communication	802.11b/g/n (2.4G) ⁽²⁾
Configuration method	Mobile Application and Website
Electrical	
Operating voltage	DC 5V(+/-5%)
Operating power consumption	≤2 W
Environment	
Operating ambient temperature range	-22°F to 149°F (-30 to +65°C)
Operating humidity	5%-95%, Relative humidity, non-condensing
Storage temperature	-40°F to 158°F (-40 to +70°C)
Storage humidity	< 40%
Max. operation altitude	13,123 ft. (4,000 m)
Protection degree	NEMA 4X
Mechanical	
Dimensions (L*W*H)	5.2*1.7*1.7 in (133*44*44 mm)
Installation method	Externally Insert + Twist Lock
Weight	0.19 lb (85 g)
Others	
Certification	CE, FCC

(1) Inverters must first be daisy-chained with RS485. (2) 5 GHz Wi-Fi networks are not supported.

S4-WiFi-ST

Solis Wi-Fi Data Logger

Description:

Up to 10 inverters can be connected to 1 data logger. The logger connects with the local Wi-Fi network and transmits data wirelessly to SolisCloud. SolisCloud, the Solis monitoring platform, allows for remote system monitoring and control. The data is clear and detailed, making it easy to monitor and troubleshoot from anywhere anytime.

Features:

- Sends alarm notifications through text and email
- Intuitive LED indicator lights displays the operating status
- Simple plug-and play installation makes commissioning quick and easy
- One button for instant data transmission and device configuration



S4-WiFi-ST

Intelligent Monitoring Solution - S4-WiFi-ST

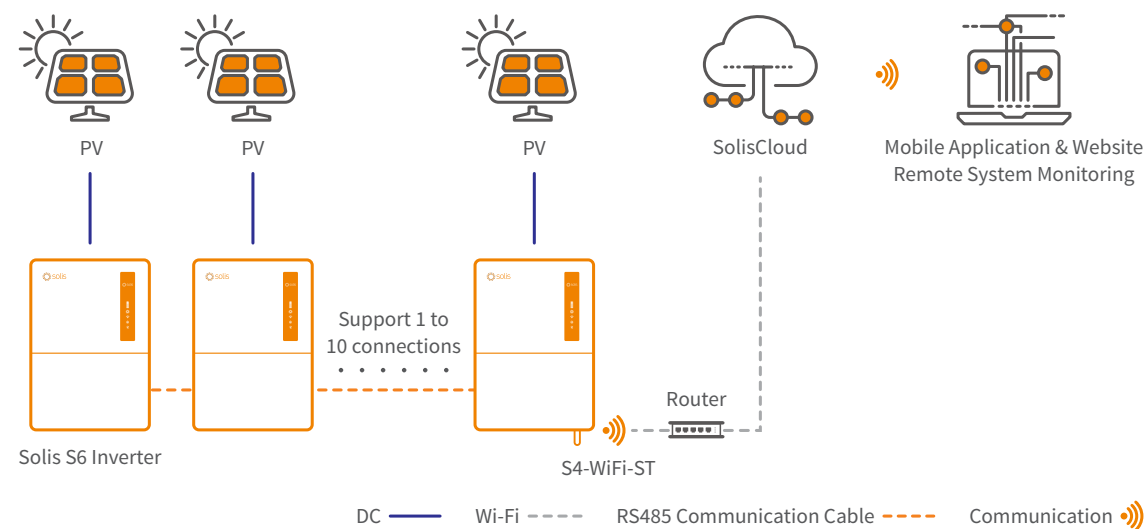

DATASHEET

S4-WiFi-ST

Models	S4-WiFi-ST
Communication	
Supported device type	Solis S6 inverter
Number of connected inverters ⁽¹⁾	≤10
Data collection intervals	5 minutes
Status indicator	3 LED Indicator Lights
Inverter connection interface	External USB Port
Wireless communication	WiFi: 802.11b/g/n (2.4G) ⁽²⁾
Configuration method	Mobile Application and Website
Electrical	
Operating voltage	DC 5V(+/-5%)
Operating power consumption	≤2 W
Environment	
Operating ambient temperature range	-22°F to 149°F (-30 to +65°C)
Operating humidity	5%-95%, Relative humidity, non-condensing
Storage temperature	-40°F to 158°F (-40 to +70°C)
Storage humidity	< 40%
Max. operation altitude	13,123 ft. (4,000 m)
Protection degree	NEMA 4X
Mechanical	
Dimensions (L*W*H)	4.4*2*1.3 in (113*50*34 mm)
Installation method	Externally Insert + Tab Lock
Weight	0.14 lb (65 g)
Others	
Certification	CE, FCC

(1) Inverters must first be daisy-chained with RS485. (2) 5 GHz Wi-Fi networks are not supported.

S1-W4G-ST

Solis Wi-Fi&Cellular Data Logger

Models: S1-W4G-ST (4 Pin) and S1-W4G-ST (USB)

Description:

A data monitoring device that plugs externally into the bottom of the inverter. The logger relays information from the inverter to the Solis monitoring platform, SolisCloud. It can connect to a local router through Wi-Fi or to a 4G cellular network. If the Wi-Fi network goes down, the logger automatically switches to using the cellular network to limit the loss of data. There are two versions of the logger, USB for S6 hybrid inverter models and 4-pin for all other Solis inverter models.

Features:

- Provides detailed system information for remote troubleshooting
- Comes with both Wi-Fi and 4G cellular communication options
- Automatically switches over to cellular when the Wi-Fi fails
- Relays system fault alarms to the Solis monitoring portal
- Supports up to ten (10) inverters per logger ⁽¹⁾
- 5-year and 10-year data plan options ⁽²⁾
- Works with all Solis inverter models ⁽³⁾
- Allows for remote firmware updates
- Quick, easy, and safe to install
- LED status indicator lights
- 2-year warranty included
- NEMA 4X outdoor rated



S1-W4G-ST (4 Pin)

S1-W4G-ST (USB)

Intelligent Monitoring Solution - S1-W4G-ST

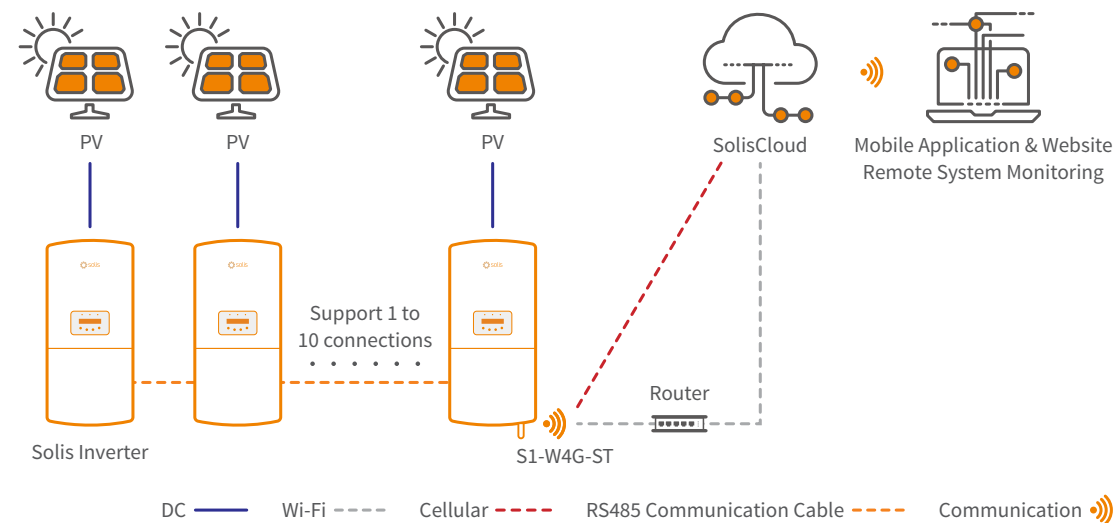

(1) Inverters must first be daisy-chained together with RS485. (2) Data plan cost is included in the price of the logger.

(3) For S6-EH1P(3.8-11.4)K-H-US models, S1-W4G-ST-USB must be used.

DATASHEET

S1-W4G-ST

Models	S1-W4G-ST (4 Pin)	S1-W4G-ST (USB)
Communication		
Supported device type	All Solis models except for S6-EH1P(3.8-11.4)K-H-US models	Only S6-EH1P(3.8-11.4)K-H-US models
Number of connected inverters ⁽¹⁾	≤10	
Data collection intervals	5 minutes	
Status indicator	3 LED Indicator Lights	
Inverter connection interface	External 4-Pin Port	External USB Port
Wireless communication	WiFi: 802.11b/g/n (2.4G) ⁽²⁾ Verizon, AT&T, T-Mobile, Rogers, & Telus 4G cellular networks (included SIM card) ⁽³⁾	
Near end communication	BLE4.2	
Configuration method	Mobile Application and Website	
Electrical		
Operating voltage	DC 5 V (+/-5%)	
Operating power consumption	≤5 W	
Environment		
Operating ambient temperature range	-22°F to 149°F (-30 to +65°C)	
Operating humidity	5%-95%, Relative humidity, non-condensing	
Storage temperature	-40°F to 158°F (-40 to +70°C)	
Storage humidity	< 40%	
Max. operation altitude	13,123 ft. (4,000 m)	
Protection degree	NEMA 4X	
Mechanical		
Dimensions (L*W*H)	5*2*1.3 in (128*50*34 mm)	4.4*2*1.3 in (113*50*34 mm)
Installation method	Externally Insert + Twist Lock	Externally Insert + Tab Lock
Weight	0.18 lb (80 g)	0.14 lb (65 g)
Others		
Certification	CE, FCC	

(1) Inverters must first be daisy-chained with RS485. (2) 5 GHz Wi-Fi networks are not supported. (3) A third-party SIM card can be used instead.

S2-PLC-CCO

Solis PLC Central Controller

S2-PLC-CCO (CCO: Central Controller) is applied in PV systems to achieve power line communication. Power Line Communication is transmission of data over the AC Wires of the system.

Features:

- No need to lay communication cables, reducing construction costs and maintenance costs
- Strong anti-interference ability
- Support multi-terminal networking
- Stable network connection, real-time data transmission



S2-PLC-CCO

Intelligent Monitoring Solution - S2-PLC-CCO

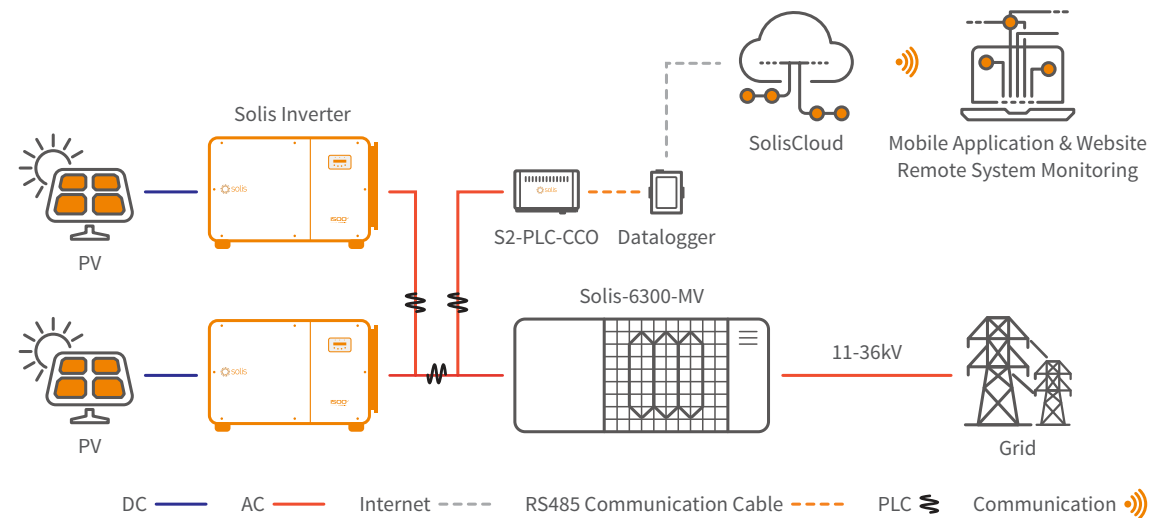

DATASHEET

S2-PLC-CCO

Models	S2-PLC-CCO
Communication	
Supported device type	Solis inverter
Number of connected inverters	≤80
Status indicator	4 LED Indicator Lights
Frequency band	2MHz-12MHz
Communication interface	4pin/RJ45/RS485
Debugging interface	Bluetooth
Baud rate	9600/19200/57600/115200
Electrical	
Input voltage (Power adapter)	12Vdc
Input current (Power adapter)	2Amax
AC port input line voltage	50-920 V, 50 Hz / 60 Hz
Operating power consumption	<5 W
Environment	
Operating ambient temperature range	-40°F to 158°F (-40 to +70°C)
Operating humidity	5%-95%, relative humidity no condensation
Storage temperature	-40°F to 194°F (-40 to +90°C)
Storage humidity	5%-95%, relative humidity no condensation
Max. operation altitude	13,123 ft. (4,000 m)
Protection degree	Indoor use only
Mechanical	
Dimensions (L*W*H)	10*6.5*1.8 in (255*165*45 mm)
Installation method	Hanging ear mounting, rail mounting
Weight	1.65 lbs (750 g)

Contact Us

HQ

- +86 574 6580 2188
- sales@ginlong.com service@ginlong.com
- 188 Jinkai Road, Binhai Industrial Park, Xiangshan, Ningbo, Zhejiang, 315712, China

UK

- +44 113 328 0870 (sales) +44 1514 536515 (service)
- europesales@solisinverters.com euservice@solisinverters.com
- 1 Church Street Bootle Liverpool, L20 1AF, UK

Mexico

- +86 574 6580 2188 (sales) +52 81 3434 2092 (service, WhatsApp only)
- sales@ginlong.com service.latam@solisinverters.com
- Monterrey, Mexico

South Africa

- +27 010 222 0181
- sales@ginlong.com saservice@solisinverters.com
- 1487 Seilskip Road, Laser Park, Honeydew, Roodepoort, Gauteng, South Africa

Poland

- +44 113 328 0870 (sales) +48 221 031 937 (service)
- europesales@solisinverters.com plservice@solisinverters.com
- Warsaw, Poland

Spain (EU Service Center)

- +34 914 430 810 (sales) +34 919 495 286 (service Spain)
- europesales@solisinverters.com (sales)
spservice@solisinverters.com (service Spain)
euservice@solisinverters.com (service EU)
- Calle de Serrano, 240 - 1ª planta 28016 Madrid, Spain

Korea

- +82 32 822 2188 (sales) +82 10 7924 2198 (service)
- krsales@solisinverters.com (sales & service)
- #A-615, Smart Valley, 30 Songdomirae-ro, yeonsu-gu, Incheon, Korea

Malaysia

- +86 574 6580 2188 (sales) +60 0162323512 (service)
- sales@ginlong.com service@ginlong.com
- Jalan Kelang Lama, 58200 Kuala Lumpur, Malaysia

Australia

- +61 3 8555 9516
- sales@solisinverters.com.au service@solisinverters.com.au
- No. 5 / 109 Tulip Street, Cheltenham, Vic. 3192 Australia

Vietnam

- +84 98 316 8126 (sales) +84 24 7109 7614 (service)
- sales@ginlong.com service@ginlong.com
- 38/21 Đ. Lố Ổ, Xã Bình Thắng, Dĩ An, Bình Dương, Việt Nam

India

- +91 224 9744 251 (sales) +91 90906 09037 (service)
- indiasales@ginlong.com inservice@solisinverters.com
- 104, wing -A, 1st floor, Techno1 City Premises Plot no. X-4/1 Mahape Navi Mumbai- 400710, India

USA/ Canada

- +1 866 438 8408
- ussales@solisinverters.com usservice@solisinverters.com
- 12333 Sowden Rd Ste B #30327, Houston TX 77080 USA

Benelux (Belgium, Netherlands, Luxembourg)

- +31 85 048 1300
- benelux@solisinverters.com (sales & service)
beservice@solisinverters.com (service Belgium)
nlservice@solisinverters.com (service Netherlands)
- Westerwerf 3-D, 1911 JA Uitgeest, Nederland

Chile

- +86 574 6580 2188 (sales)
- +52 811 500 2841 (service) +52 33 1751 0488 (service)
- sales@ginlong.com service@ginlong.com

Thailand

- +86 574 6580 2188 (sales) +66 099 050 5595 (service)
- sales@ginlong.com service@ginlong.com
- Vibhavadi Rangsit Road, Chatucha, Bangkok 10900, Thailand

Brazil

- +55 19 996133803 (sales) +55 19 999618000 (service, WhatsApp)
- sales@ginlong.com service@ginlong.com
- Rua James Clerk Maxwell, nº 280, Unidade 07, Empresa Solis, Bairro Parque Tecnológico Techno Park, Condomínio Empresarial Aztech, Campinas, SP, CEP 13.069-380

Germany

- +49 800 5369147 (service)
- europesales@solisinverters.com deservice@solisinverters.com

Sweden

- +46 761 472 195 (sales) +46 850 282 408 (service)
- europesales@solisinverters.com seservice@solisinverters.com
- Åkersberga, Sweden

Romania

- +40 373 808 894 (service)
- europesales@solisinverters.com euservice@solisinverters.com
- Brasov, Romania

Myanmar

- +86 574 6580 2188 (sales) +95 94 302 3335 (service)
- sales@ginlong.com service@ginlong.com
- No (10) Sagwar Pin Street, Kyimyindaing, Yangon City

Ireland

- +353 1592 0312 (service)
- europesales@solisinverters.com euservice@solisinverters.com
- Dublin, Ireland

Austria

- +43 800 070 634(service)
- europesales@solisinverters.com deservice@solisinverters.com
- Vienna, Austria

Greece

- +30 8000000227 (service)
- europesales@solisinverters.com grservice@solisinverters.com
- Athens, Greece

Lithuania

- +370 609 99959 (service)
- europesales@solisinverters.com ltservice@solisinverters.com

Philippines

- +86 574 6580 2188 (sales) +63 2 8372 7945 (service)
- sales@ginlong.com phservice@solisinverters.com
- 40 Nadurata St. Zone 5 Brgy. 53 Grace Park West , Caloocan City, Metro Manila, Philippines

Pakistan

- +86 574 6580 2188 (sales)
- +92 304 1119118 (service) +92 334 1171144 (service, WhatsApp)
- sales@ginlong.com service@ginlong.com
- Plot#07, Opposite Usman Carpet, Defence Road, Lahore, Pakistan

Singapore

- +86 574 6580 2188 (sales) +60 016 232 3512 (service)
- sales@ginlong.com service@ginlong.com

Turkey

- +90 545 651 3541
- europesales@solisinverters.com euservice@solisinverters.com
- Istanbul, Turkey

Indonesia

- +86 574 6580 2188 (sales) +62 081385918539 (service)
- sales@ginlong.com service@ginlong.com
- Kunciran Pinang, Tangerang, Indonesia

France

- +34 914 430 810 (sales) +33 971 078 736 (service)
- europesales@solisinverters.com euservice@solisinverters.com
- Paris, France

Portugal

- +351 80 050 6138 (service)
- europesales@solisinverters.com poservice@solisinverters.com
- Lisbon, Portugal

Sri Lanka

- +86 574 6580 2188
- sales@ginlong.com service@ginlong.com
- Colombo, Sri Lanka

Switzerland

- +41 800 563 032 (service)
- europesales@solisinverters.com deservice@solisinverters.com
- Zurich, Switzerland

Italy

- +39 02 8295 7352
- europesales@solisinverters.com itservice@solisinverters.com

